



# CITY OF PHILOMATH CITY COUNCIL

**June 10, 2024**

City Hall Council Chambers  
980 Applegate St., Philomath, OR 97370

## **Mission Statement**

To promote ethical and responsive municipal government which provides its citizenry with high quality municipal services in an efficient and cost effective manner.

## **REGULAR MEETING**

**7:00 pm**

### **A. ROLL CALL**

### **B. PRESENTATION**

1. OCWCOG Update - Ryan Vogt, Oregon Cascades West Council of Governments Executive Director
2. Twenty-year Service Recognition – David Gurski, Chief of Police

### **C. PUBLIC HEARINGS**

1. Supplemental FY 2023-2024 Budget (no public hearing)
  - a) Resolution 24-14 Adopting Supplemental FY 2023-2024 Budget
2. Proposed uses of State Revenue Sharing for FY 2024-2025
  - a) Public Hearing
  - b) Resolution 24-15 Electing to Receive State Revenue Sharing
3. FY 2024-2025 City Budget
  - a) Public Hearing
  - b) Resolution 24-16 Imposing & Categorizing Taxes for FY 2024-2025 Budget
  - c) Resolution 24-17 Adopting & Appropriating FY 2024-2025 City Budget

### **D. PROCLAMATION**

1. Resolution 24-13, Re-affirming Inclusivity Proclamation 20-11

### **E. PUBLIC COMMENTS (See Meeting Participation Instructions on Page 2)**

This time is intended for individuals to speak and Council to listen. Members of the Council will not discuss topics or make decisions during this time, but may take comments or requests under advisement, assign topics to a future Council or Standing Committee agenda, or request staff to take action. Comments about a topic scheduled for a public hearing should be given during the hearing, not during visitors and comments. Testimony time is limited to 3-minutes per speaker; a 30-second warning will be provided. Speakers should provide their name and city of residence. Providing the Council with written copy of your comments prior to or during the meeting is greatly appreciated. Those who attend public meetings are required to adhere to the council's rules of proceedings and observe the same standards of decorum as members of the council. Further, at the discretion of the presiding officer, members of the public who fail to observe these rules of procedure will be asked to discontinue speaking and will not be allowed to speak again for the remainder of the meeting.

1. The College of Philomath Community Project Update – Scott Ramsey

### **F. CONSENT AGENDA**

1. City Council Work Session Notes of May 13, 2024
2. City Council Minutes of May 13, 2024

### **G. REPORTS OF BOARDS, COMMISSIONS, COMMITTEES, COUNCIL LIAISONS AND STAFF**

1. Management Report

## INFORMATION & CORRESPONDENCE

1. June City Newsletter
2. YouTube Channel Views Report: May 2024
3. Philomath Connection bus ridership for May 2024
4. Planning Commission Staff Update
5. Planning Commission Minutes of May 20, 2024
6. Park Advisory Board Minutes of May 7, 2024
7. Police Committee Minutes of May 14, 2024
8. Budget Committee Minutes of May 15, 2024
9. Budget Committee Minutes of May 22, 2024
10. City Council Outreach Sign-up for Farmers' Market & Music in the Park
11. RAIN Catalysts 2024 Quarter 1 Engagement Report
12. Inclusivity Committee Minutes of April 23, 2024
13. Inclusivity Committee Minutes of May 28, 2024

## H. ADJOURNMENT

### **MEETING PARTICIPATION INSTRUCTIONS**

This meeting is being held in-person at the City Hall Council Chambers, and the public is invited to attend. Public comments and testimonies are also available via written or electronic participation. City meetings are live-streamed on the City's YouTube channel at: [City of Philomath - YouTube](#). This is a public page; no account or user fee is required.

Given two business days' notice, an interpreter can be provided for the hearing impaired or those with limited proficiency in English.

Contact the City Manager's Office to make interpreter arrangements:  
541-929-6148; [cityhall@philomathoregon.gov](mailto:cityhall@philomathoregon.gov); PO Box 400, Philomath, OR 97370

#### **Opportunities to Comment**

##### Methods:

1. Appear at City Hall Council Chambers
2. Sign up to speak via phone or Zoom by contacting City Hall
3. Email written comments to City Hall
4. Deliver written comments to City Hall
5. Mail written comments to City Hall

##### Must be received by:

- 4:00 p.m. the day of the meeting
- 12:00 p.m. the day of the meeting
- 12:00 p.m. the day of the meeting
- 12:00 p.m. the day of the meeting

### **UPCOMING CITY MEETING AND EVENTS**

(as of 6/6/2024)

June 9	11-3:00 PM	Philomath Farmers' Market
June 10	7:00 PM	City Council & Urban Renewal Agency Meeting
June 15	Noon-4 PM	3 <sup>rd</sup> Annual Pride Event at City Park
June 16	11-3:00 PM	Philomath Farmers' Market
June 17	6:00 PM	Planning Commission Meeting
June 19	All Day	Juneteenth Holiday, City offices closed
June 20	6-8:00 PM	Music in the Park
June 23	11-3:00 PM	Philomath Farmers' Market
June 25	5:30 PM	Inclusivity Committee Meeting
June 30	11-3:00 PM	Philomath Farmers' Market (McMorran & Andrade)
June 30	6-8:00 PM	Music in the Park

Meetings may be cancelled or postponed. Refer to the City Meetings & Events calendar on the City's website for the most up-to-date meeting information.



# Philomath

## 2023 Annual Report

### Senior & Disability Services

#### CASE MANAGEMENT & ELIGIBILITY



**42**  
CASES  
MANAGED

In addition to the current Long-term Services and Supports case load, staff processed **44** new service requests from Lebanon residents.

**431**

AVERAGE ACTIVE  
MEDICAL CASES IN  
PHILOMATH

#### ADULT PROTECTIVE SERVICES

**50** Adult Protective Services (APS) investigations took place in 2023. This accounted for **11%** of APS investigations in Benton County.

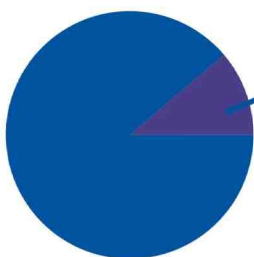

Philomath  
APS  
Investigations  
in 2023

### 5 OREGON PROJECT INDEPENDENCE CONSUMERS

Oregon Project Independence is an alternative to Medicaid that supports daily living activities which can be provided by home care workers or in-home care agencies.

#### MEALS ON WHEELS

The Corvallis Meals on Wheels site served **40** Philomath residents in 2023 a total of **6,315** meals.



**6,237**  
HOME DELIVERED  
MEALS



**78**  
IN-PERSON  
MEALS



**39**  
SHELF-STABLE  
FOOD BOXES



# 1 FOSTER GRANDPARENT VOLUNTEER

Provided **1,577** volunteer hours serving at Philomath Elementary.



# AARP VOLUNTEERS HELPED WITH TAX PREP FOR SENIORS

AARP Tax Aid volunteers helped prepare 2022 taxes from January to April at the Philomath Public Library free of charge for seniors.

## Community Service Programs

### SENIOR HEALTH INSURANCE BENEFITS ASSISTANCE

**38** Corvallis residents received one-on-one counseling on their Medicare benefits through the Senior Health Insurance Benefits Assistance (SHIBA) program. **1** Medicare 101 seminar was held in Philomath, and **1** resident volunteered as a coach for the program during 2023.

## Community & Economic Development



### CASCADES WEST RIDE LINE

Provided 1,305 rides

Cascades West Ride Line coordinates transportation services for eligible Oregon Health Plan (OHP) and Medicaid clients traveling to and from covered non-emergency medical services.



### PHILOMATH BLVD DESIGN EFFORTS

Between 53rd & 15th

CAMPO is working with a consultant to develop functional designs to provide solutions to this area of Philomath Boulevard and is preparing to apply for grant funding for the project.



### CLIMATE FRIENDLY AREAS

Draft provided in June

Provided a draft of Climate Friendly Areas for the city. These areas are places where people can live, work, and meet most of their daily needs without having to drive a car.

### CASCADES WEST BUSINESS LENDING

Cascades West Business Lending supports small businesses in Philomath with **1** Active loan creating at least **5** jobs in the city.

### EATS AND TREATS CAFE





## Philomath City Council Agenda Item Summary

Title/Topic: Resolution 24-14 – 2023-24 Fiscal Year Supplemental Budget

---

Meeting Date: June 10, 2024

Staff Contact: Mike Murzynsky, Finance Director

---

### **ISSUE STATEMENT**

Shall the City Council adopt Resolution 24-14 which approves the final 2023-24 Fiscal Year Supplemental Budget and making appropriation/total requirement changes.

### **BACKGROUND**

The supplemental budget presented to the City Council this evening contains adjustments to various funds as recommended by City staff based on their review of their budgets for the current fiscal year 2023-24. Other budget adjustments are noted as each fund is detailed. The details by fund are as follows:

#### **General Fund**

Based on year-end projections used in the budget process for the 2024-25 fiscal year, the following departments require an adjustment for “salary and benefit” costs as they will exceed their budgets. The departments and amount are:

- |                           |          |
|---------------------------|----------|
| 1) City Manager           | \$15,000 |
| 2) Assistant City Manager | \$15,000 |
| 3) Finance Director       | \$10,000 |
| 4) Chief of Police        | \$10,000 |

The Finance and Court departments also have increased Legal costs of \$6,000 and \$18,000, respectively, due to retirement of the City Attorney.

The planned Holiday Décor Revenue was reduced from \$5,000 to \$0.00 and was replaced by ARPA dollars in the amount of \$12,000. In turn the line item 10-9-5305 Holiday Décor will be increased by \$12,000.

The City Planning department added an Associate Planner for \$32,000 and an offset of revenue from Adair, Monroe, and Benton County in the amount of \$16,000 has been created.

These items required the use of General Contingency in the amount of \$107,000.

#### **Land, Building & Equipment fund (LBE) (41):**

At year-end, we are moving \$150,000 of ARPA monies from the General Fund, decreasing line item, 10-9-5790 ARPA Projects, and increasing line item 10-9-8500, Transfer to LBE fund.

In the LBE fund the incoming transfer line item, 41-0-3940, Transfer from General Fund will be increased by \$150,000. The following line items will be increased:

- |              |                               |          |
|--------------|-------------------------------|----------|
| 1) 41-0-6457 | 13 <sup>th</sup> Street Lites | \$80,000 |
| 2) 41-0-6467 | Starlight Pump                | \$60,000 |
| 3) 41-0-6434 | Cochran Memorial              | \$10,000 |

**Fiscal Notes:**

The total City budget has increased by \$161,000 with a new appropriation balance of \$35,675,884 which represents a .04533% increase over the total (adjusted) adopted budget of \$35,514,884.

STAFF RECOMMENDATION

Staff recommends Council adopt 24-14 as outlined in the above notes.

RECOMMENDED MOTION

I move to adopt Resolution No. 24-14, a resolution adopting a supplemental budget for fiscal year 2023-24 and making appropriation increases and changes for fiscal year 2023-24, incorporating Attachment "A" as part of the resolution.

ATTACHMENTS

Resolution 24-14

Resolution 24-14 Attachment A: 2023-24 Budget Roll-forward



## CITY OF PHILOMATH RESOLUTION 24-14

### **A RESOLUTION ADOPTING A SUPPLEMENTAL BUDGET ADJUSTMENT FOR FISCAL YEAR 2023-24, MAKING APPROPRIATION/TOTAL REQUIREMENT CHANGES FOR SPECIFIC FUNDS**

**WHEREAS**, the City of Philomath's 2023-2024 Fiscal Year budget requires changes of appropriation for the General Fund and the Land, Building & Equipment fund to unplanned circumstances and have complied with the provisions of ORS 294.

**WHEREAS**, under the provisions of Oregon Local Budget Law, fund accounts are required to reflect sufficient authorized appropriations consistent with available resources; and

**WHEREAS**, ORS 294.471 allows a supplemental budget for an occurrence for conditions not ascertained while preparing the current budget, or if the amended estimated expenditures contained in an individual fund that is being changed by a supplemental budget differ by 10 percent or less from the expenditures in the budget as most recently amended prior to the supplemental budget, the governing body of the municipal corporation may adopt the supplemental budget at a regular meeting of the governing body; and

**THE CITY OF PHILOMATH RESOLVES AS FOLLOWS:** that this supplemental budget is hereby adopted and hereby provides for:

**Section 1. Within the General Fund:**

1. Adjust salary and benefit costs for the City Manager, Finance, and Police departments.
2. Increase the Legal cost for Finance and Court.
3. Increase Downtown Holiday Décor line item.
4. Addition of Associate Planner position and related offset revenue from City of Adair and Monroe plus Benton County.
5. Move ARPA dollars via an increased Transfer Out to the LBE fund.

**Section 2. Within the Land, Building and Equipment fund:**

1. Record the receipt of ARPA funds from the General Fund.
2. Increase budgets related to the 13<sup>th</sup> Street Lights, Starlight Pump, and Cochran Memorial Park projects.

These additional appropriations are hereby authorized, and Attachment A sets forth the supplemental budgets listed above and as such Attachment A is incorporated herein.

Adopted by the Philomath City Council on June 10, 2024.

Signed by the Mayor on June 10, 2024

SIGNED:

ATTEST:

\_\_\_\_\_  
Chas Jones, Mayor

\_\_\_\_\_  
Ruth Post, MMC, City Recorder

CITY OF PHILOMATH  
Budget with Supplements/Transfer Resolutions - ATTACHMENT A  
Fiscal Year 2023-2024

		Date	7/1/2023 Adopted Budget 23-14	6/10/2024 Resolution 24-14	Total Adjusted Budget
<b>Fund</b>	<b>Appropriation Level</b>				
<b>101-General Fund</b>					
	Beginning Fund Balance		2,341,120		2,341,120
	Revenues		4,069,031	11,000	4,080,031
			<b>Total Revenues:</b>		6,421,151
<b>101-General Fund</b>					
	City Administration		1,751,707	106,000	1,857,707
	Police		1,690,661		1,690,661
	Buildings & Grounds		140,355		140,355
	Parks		174,488		174,488
	City Council		364,831	(138,000)	226,831
	Transfer to Street Fund		69,652		69,652
	Transfer to Land, Building & Equipment (LBE)		218,240	150,000	368,240
	Contingency Account		241,218	(107,000)	134,218
			<b>Total Appropriations:</b>		4,662,152
	Unappropriated Ending Fund Balance		1,758,999		1,758,999
			<b>Total General Fund</b>		6,421,151
<b>GENERAL FUND - 101</b>					
<b>16 - Development Review</b>					
	Beginning Fund Balance		1,291		1,291
	Revenues		152,000		152,000
			<b>Total Revenues:</b>		153,291
<b>16 - Development Review</b>					
	Materials & Services		152,000		152,000
	Contingency Account		-		-
			<b>Total Appropriations:</b>		152,000
	Unappropriated Ending Fund Balance		1,291		1,291
			<b>Total Development Review Fund</b>		153,291
<b>Development Review</b>					
<b>21 - Street</b>					
	Beginning Fund Balance		327,057		327,057
	Revenues		724,227		724,227
	Transfers In		69,652		69,652
			<b>Total Revenues:</b>		1,120,936
<b>21 - Street</b>					
	Street Maintenance		738,298		738,298
	Transfer to LBE Fund		234,101		234,101
	Contingency Account		104,500		104,500
			<b>Total Appropriations:</b>		1,076,899
	Unappropriated Ending Fund Balance		44,037		44,037
			<b>Total Street Fund</b>		1,120,936
<b>STREET FUND - 21</b>					
<b>22 - Community Development</b>					
	Beginning Fund Balance		121,376		121,376
	Revenues		31,208		31,208
	Transfers In		-		-
			<b>Total Revenues:</b>		152,584
<b>22 - Community Development</b>					
	Downtown Loan Program		110,000		110,000
	Transfers Out		-		-
	Contingency Account		-		-
			<b>Total Appropriations:</b>		110,000
	Unappropriated Ending Fund Balance		42,584		42,584
			<b>Total Community Development Fund</b>		152,584

**CITY OF PHILOMATH**  
**Budget with Supplements/Transfer Resolutions - ATTACHMENT A**  
**Fiscal Year 2023-2024**

		Date	7/1/2023 Adopted Budget 23-14	6/10/2024 Resolution 24-14	Total Adjusted Budget
<b>Fund Appropriation Level</b>					
<b>Community Development Fund - 22</b>					
<b>32 - Economic Development</b>					
	Beginning Fund Balance		12,901		12,901
	Revenues		43,884		43,884
<b>Total Revenues:</b>			56,785	-	56,785
<b>32 - Economic Development</b>					
	OECDD - Principal & Interest		47,746		47,746
	Contingency Account		-		-
<b>Total Appropriations:</b>			47,746	-	47,746
	Unappropriated Ending Fund Balance		9,039		9,039
<b>Total Economic Development Fund</b>			56,785	-	56,785
<b>Economic Development - 32</b>					
<b>41 - Land, Building &amp; Equipment</b>					
	Beginning Fund Balance		5,113,142		5,113,142
	Revenues		1,051,747	9,036,456	10,088,203
	<b>Biz Oregon Grant - HB 5006 (Loan category)</b>		9,036,456	(9,036,456)	-
	Transfer from Other Funds		1,541,440	150,000	1,691,440
<b>Total Revenues:</b>			16,742,785	150,000	16,892,785
<b>41 - Land, Building &amp; Equipment</b>					
41-0-6403	Administration Equipment		6,000		6,000
41-0-6405	Bus Services		63,000		63,000
41-0-6411	Finance Equipment		6,000		6,000
41-0-6415	Court Equipment		6,000		6,000
41-0-6422	Police Office Equipment		2,000		2,000
41-0-6424	Police Equipment		4,500		4,500
41-0-6426	Police Vehicle		-		-
41-0-6430	B & G Equipment		-		-
41-0-6432	Park Equipment		-		-
41-0-6434	Park Buildings and Land		155,000	10,000	165,000
41-0-6441	City Hall Building		30,000		30,000
41-0-6443	Police Building		24,000		24,000
41-0-6447	Library Building		30,000		30,000
41-0-6457	Street Infrastructure		250,000	80,000	330,000
41-0-6459	Bike Path		2,000		2,000
41-0-6463	Water Equipment		-		-
41-0-6467	Water Infrastructure		9,805,456	60,000	9,865,456
41-0-6473	Sewer Equipment		-		-
41-0-6477	Sewer Infrastructure		1,660,000		1,660,000
41-0-6480	Storm Drain Infrastructure		58,000		58,000
41-0-6490	P/W office equipment		5,000		5,000
41-0-6504	Utility Rate Study		50,000		50,000
41-0-6505	N 19th St Sidewalk & Water		370,000		370,000
41-0-6493	Public Works Building		27,600		27,600
	Capital Outlay		12,554,556	150,000	12,704,556
	Contingency Account		4,188,229		4,188,229
<b>Total Appropriations:</b>			16,742,785	150,000	16,892,785
	Unappropriated Ending Fund Balance		-		-
<b>Total Land, Bldg &amp; Equipment Fund</b>			16,742,785	150,000	16,892,785
<b>Land, Building &amp; Equipment - 41</b>					

CITY OF PHILOMATH  
Budget with Supplements/Transfer Resolutions - ATTACHMENT A  
Fiscal Year 2023-2024

		Date	7/1/2023 Adopted Budget 23-14	6/10/2024 Resolution 24-14	Total Adjusted Budget
<b>Fund</b>	<b>Appropriation Level</b>				
<b>42 - SDC GOVERNMENTAL</b>					
	Beginning Fund Balance		2,339,533		2,339,533
	Revenues		518,993		518,993
	Transfer from General Fund		-		-
	<b>Total Revenues:</b>		2,858,526	-	2,858,526
<b>42 - SDC GOVERNMENTAL</b>					
	Governmental - Materials & Service		25,000		25,000
	Capital Outlay		316,100		316,100
	Contingency Account		254,000		254,000
	<b>Total Appropriations:</b>		595,100	-	595,100
	Unappropriated Ending Fund Balance		2,263,426		2,263,426
	<b>Total SDC - Governmental Fund</b>		2,858,526	-	2,858,526
<b>SDC Governmental - 42</b>			-	-	-
<b>43 - SDC PROPRIETARY</b>					
	Beginning Fund Balance		2,900,318		2,900,318
	Revenues		655,905		655,905
	<b>Total Revenues:</b>		3,556,223	-	3,556,223
<b>43 - SDC PROPRIETARY</b>					
	Proprietary - Material & Services		15,000		15,000
	Capital Outlay		100,000		100,000
	Transfer to other funds		250,000		250,000
	Contingency Account		500,000		500,000
	<b>Total Appropriations:</b>		865,000	-	865,000
	Reserve for Future Expenditures		-		-
	Unappropriated Ending Fund Balance		2,691,223		2,691,223
	<b>Total SDC - Proprietary Fund</b>		3,556,223	-	3,556,223
<b>SDC GOVERNMENTAL - 43</b>			-	-	-
<b>51 - Water</b>					
	Beginning Fund Balance		41,501		41,501
	Revenues		1,804,391		1,804,391
	Transfers In		-		-
	<b>Total Revenues:</b>		1,845,892	-	1,845,892
<b>51 - Water</b>					
	Operations		1,154,041		1,154,041
	Transfers Out		507,904		507,904
	Contingency Account		117,127		117,127
	<b>Total Appropriations:</b>		1,779,072	-	1,779,072
	Reserve for Future Expenditures		-		-
	Unappropriated Ending Fund Balance		66,820		66,820
	<b>Total Water Fund</b>		1,845,892	-	1,845,892
<b>WATER - 51</b>			-	-	-
<b>52 - Wastewater</b>					
	Beginning Fund Balance		582,753		582,753
	Revenues		1,635,064		1,635,064
	Transfers In		250,000		250,000
	<b>Total Revenues:</b>		2,467,817	-	2,467,817
<b>52 - Wastewater</b>					
	Operations		984,678		984,678
	Debt Service		421,600		421,600
	Transfer to Capital Projects - Proprietary Fund		551,195		551,195
	Contingency Account		135,866		135,866
	<b>Total Appropriations:</b>		2,093,339	-	2,093,339
	Reserve for Future Expenditures		-		-
	Unappropriated Ending Fund Balance		374,478		374,478
	<b>Total Wastewater Fund</b>		2,467,817	-	2,467,817
<b>Wastewater - 52</b>			-	-	-

CITY OF PHILOMATH  
Budget with Supplements/Transfer Resolutions - ATTACHMENT A  
Fiscal Year 2023-2024

		Date	7/1/2023 Adopted Budget 23-14	6/10/2024 Resolution 24-14	Total Adjusted Budget
<b>Fund</b>	<b>Appropriation Level</b>				
<b>53 - Storm Water</b>					
	Beginning Fund Balance		48,838		48,838
	Revenues		101,056		101,056
	Transfers In		-		-
	<b>Total Revenues:</b>		149,894	-	149,894
<b>53 - Storm Water</b>					
	Stormwater Maintenance		66,668		66,668
	Transfers Out		30,000		30,000
	Contingency Account		30,000		30,000
	<b>Total Appropriations:</b>		126,668	-	126,668
	Reserve for Future Expenditures		-		-
	Unappropriated Ending Fund Balance		23,226		23,226
	<b>Total Storm Water Fund</b>		149,894	-	149,894
<b>Storm Water - 53</b>			-	-	-
	<b>Total Appropriations:</b>				
<b>CITY'S BALANCING AMOUNTS:</b>					
	TOTAL RESOURCES:		35,514,884	161,000	35,675,884
	TOTAL APPROPRIATIONS		28,239,761	161,000	28,400,761
	TOTAL NON APPROPRIATIONS		7,275,123	-	7,275,123
	TOTAL DISTRIBUTIONS		35,514,884	161,000	35,675,884
<b>TOTAL CITY BUDGET BALANCE</b>			-	-	-
	TRANSFERS IN:		1,861,092	150,000	2,011,092
	TRANSFERS OUT:		1,861,092	150,000	2,011,092
	URA TRANSFERS IN:				-
	URA TRANSFERS OUT:				-
			-	-	-

**CITY OF PHILOMATH**  
**Budget with Supplements/Transfer Resolutions - ATTACHMENT A**  
**Fiscal Year 2023-2024**

Date	7/1/2023 Adopted Budget 23-14	6/10/2024 Resolution 24-14	Total Adjusted Budget
------	-------------------------------------	----------------------------------	--------------------------

Fund	Appropriation Level	7/1/2023 Adopted Budget	6/10/2024 Resolution 24-14	Total Adjusted Budget
<b>Philomath URBAN RENEWAL AGENCY</b>				
<b>Budget with Supplements/Transfer Resolutions - ATTACHMENT A</b>				
<b>Fiscal Year 2023-2024</b>				
<hr/>				
<b>7/1/2023</b>				
<b>Adopted Budget</b>				
<b>Total Adjusted</b>				
<b>Budget</b>				
<hr/>				
<b>23 - Urban Renewal Agency</b>				
	Beginning Fund Balance	15,202		15,202
	Revenues	824,785		824,785
	Transfers In	-		-
<b>Total Revenues:</b>		<b>839,987</b>	<b>-</b>	<b>839,987</b>
<hr/>				
<b>23 - Urban Renewal Agency</b>				
	Materials & Services	93,146		93,146
	Capital Outlay	500,000		500,000
	Debt Service	226,494		226,494
	Contingency Account	-		-
<b>Total Appropriations:</b>		<b>819,640</b>	<b>-</b>	<b>819,640</b>
	Reserve for Future Expenditures	-		-
	Unappropriated Ending Fund Balance	20,347		20,347
<b>Total Urban Renewal Agency Fund</b>		<b>839,987</b>	<b>-</b>	<b>839,987</b>
<hr/>				
<b>URBAN RENEWAL AGENCY FUND - 23</b>				
<hr/>				
<b>URA's BALANCING AMOUNTS:</b>				
	TOTAL RESOURCES:	839,987	-	839,987
	TOTAL APPROPRIATIONS	819,640	-	819,640
	TOTAL NON APPROPRIATIONS	20,347	-	20,347
	TOTAL DISTRIBUTIONS	839,987	-	839,987
<hr/>				
<b>TOTAL URA BUDGET BALANCE</b>				
<hr/>				
	TRANSFER IN:	-	-	-
	TRANSFER OUT:	-	-	-
	CITY TRANSFERS IN:	1,861,092	150,000	2,011,092
	CITY TRANSFERS OUT:	1,861,092	150,000	2,011,092
		<hr/>	<hr/>	<hr/>
<hr/>				
<b>CITY'S &amp; URA's BALANCING AMOUNTS:</b>				
	TOTAL RESOURCES:	36,354,871	161,000	36,515,871
	TOTAL APPROPRIATIONS	29,059,401	161,000	29,220,401
	TOTAL NON APPROPRIATIONS	7,295,470	-	7,295,470
	TOTAL DISTRIBUTIONS	36,354,871	161,000	36,515,871
<hr/>				
<b>TOTAL CITY BUDGET BALANCE</b>				
<hr/>				
	TRANSFER IN:	1,861,092	150,000	2,011,092
	TRANSFER OUT:	1,861,092	150,000	2,011,092
		<hr/>	<hr/>	<hr/>
<hr/>				



## Philomath City Council Agenda Item Summary

Title/Topic: Public Hearing on and consideration of Resolution 24-15  
**declaring the City's election to receive State Shared Revenues.**

Meeting Date: June 10, 2024,  
Department: Finance

Staff Contact: Mike Murzynsky  
Email: [mike.murzynsky@philomathoregon.gov](mailto:mike.murzynsky@philomathoregon.gov)

### ISSUE STATEMENT

To receive State Shared Revenues the City must hold two public hearings and pass a resolution to receive the various types of shared revenue.

### BACKGROUND AND FISCAL NOTES

State Revenue Sharing Law, ORS 221.770, requires cities to pass an ordinance or resolution each year stating they want to receive their share and the resolution or ordinance must be filed with the Shared Financial Services of the Oregon Department of Administrative Services before July 31. Prior to the June 10, 2024, public hearing there must be one other public hearing with the City's Budget Committee, and this was fulfilled at the April 26, 2024, Budget Committee Hearing.

Fiscal Notes: The City receives four types of state shared revenues which include general shared revenues, liquor tax, cigarette tax, highway gas tax, and marijuana tax. General Shared revenues are allocated pursuant to a different statutory formula while the distribution of the liquor, cigarette, highway gas tax, and marijuana tax are allocated on the basis of population of the City and an estimated rate per capita based on projected available taxes collected. The estimated revenues for the 2024-25 Fiscal Year are as follows (see attachment A):

General Shared Revenues	\$ 79,586 (General Fund)
Liquor Tax	\$123,681 (General Fund)
Cigarette Tax	\$ 4,134 (General Fund)
Marijuana Tax	\$ 8,036 (General Fund)
Highway gas tax	\$467,685 (Streets and Bike Paths and Trails)

These estimated revenues will impact the General Fund in the amount of \$215,007 and the Street and Capital Projects will share the \$467,685 in this order, respectively, \$463,008, and \$4,677.

### COUNCIL OPTIONS

1. Approve Resolution 24-15 as presented.

### RECOMMENDED MOTION

I move to adopt Resolution No. 24-15, a Resolution Declaring the City's Election to receive State Shared Revenues pursuant to ORS 221.770 for Fiscal Year 2024-2025.

### ATTACHMENTS

Resolution 24-15  
Oregon Shared Revenue – Attachment A

**CITY OF PHILOMATH  
RESOLUTION 24-15**

**A RESOLUTION DECLARING THE CITY'S ELECTION TO RECEIVE  
STATE SHARED REVENUES.**

**WHEREAS** ORS 221.770 requires the city of Philomath to elect to receive state revenues.

**NOW, THEREFORE**, BE IT RESOLVED BY THE CITY OF PHILOMATH that the City hereby elects to receive state revenues for fiscal year 2024-25.

PASSED by the Council on this 10th day of June 2025.

Signed:

Chas Jones, Mayor

ATTEST:

Ruth Post, MMC, City Recorder

I certify that a public hearing before the Budget Committee was held on April 26, 2024, and a public hearing before the City Council was held on June 10, 2024, giving citizens an opportunity to comment on use of State Revenue Sharing.

---

Ruth Post, MMC, City Recorder

CITY OF PHILOMATH, OREGON

2024 -25 OREGON STATE SHARED REVENUES

PUBLIC HEARING BEFORE THE BUDGET COMMITTEE ON THE POSSIBLE USES  
FISCAL YEAR 2024-25 PROPOSED BUDGET  
"ATTACHMENT A"

REVENUE TYPE	CERTIFIED EST. POPULATION	PER CAPITA RATES ESTIMATES	ESTIMATED REVENUES		
A. GENERAL SHARED REVENUES	Not Applicable	Not Applicable	\$ 79,156		
B. OTHER SHARED REVENUES					
Liquor Tax	5,823	\$ 21.24	\$ 123,681		
Cigarette Tax	5,823	\$ 0.71	\$ 4,134		
Marijuana Tax	5,823	\$ 1.38	\$ 8,036		
Highway Gas Tax	5,823	\$ 79.35	\$ 467,685	99.0% of Allocation for Streets and Roads	463,008
				1.0% of Allocation for Bicycle Paths & Trails	4,677
C. COMPARISON TO PROPOSED BUDGET REQUIREMENTS					
FY 2023-24 PROPOSED BUDGET - ALL FUNDS			\$ 40,841,518	Summary of Funds	
FY 2023-24 PROPOSED BUDGET - GENERAL FUND			\$ 6,451,757	\$ 215,007	* - See General Fund Resources
FY 2023-24 PROPOSED BUDGET - STREETS FUND FOR OPERATIONS (Fund 251)			\$ 781,989	\$ 463,008	Allocated - See Street Fund
- CAPITAL PROJECTS FUND (Fund 402)			\$ 19,865,685	\$ 4,677	Allocated - See Capital Projects Fund
Total State Gas Tax Allocation			\$ 20,647,674	\$ 467,685	

Projection data source - League of Oregon 2024 State Shared Revenue Report



## Philomath City Council Agenda Item Summary

---

Title/Topic: Imposing and Categorizing Ad Valorem Taxes for 2024-25  
Fiscal Year

---

Meeting Date: June 10, 2024  
Department: Finance

Staff Contact: Mike Murzynsky  
Email: [mike.murzynsky@philomathoregon.gov](mailto:mike.murzynsky@philomathoregon.gov)

---

### ISSUE STATEMENT

The purpose of this resolution is to consider Resolution 24-16, which imposes and categorizes Ad Valorem taxes for the City of Philomath.

### BACKGROUND

The Budget Committee approved the City Budget for Fiscal Year 2024-25 on May 22, 2024. Resolution No. 24-16 provides for imposing the Ad Valorem taxes, which balance the General Fund budget.

### COUNCIL OPTIONS

1. Approve Resolution 24-16 as presented.

### RECOMMENDED MOTION

I move to adopt Resolution No. 24-16, a resolution imposing and categorizing ad valorem taxes for the City of Philomath for the fiscal year beginning July 1, 2024, and ending June 30, 2025, at a rate of \$5.3005 per thousand dollars of assessed valuation.

### ATTACHMENTS

Resolution 24-16



**CITY OF PHILOMATH  
RESOLUTION 24-16**

**A RESOLUTION IMPOSING AND CATEGORIZING TAXES.**

**THE CITY OF PHILOMATH RESOLVES** that the following ad valorem property taxes are hereby imposed for tax year 2024-25 upon the assessed value of all taxable property within the City of Philomath at the rate of 5.3005 per \$1,000 of assessed value for the permanent rate tax; and the taxes imposed are hereby categorized for purposes of Article XI section 11b as:

	General Government Limitation
Permanent Rate Tax	5.3005/\$1,000

PASSED by the Council this \_\_\_\_\_ day of June 2024.

APPROVED by the Mayor this \_\_\_\_\_ day of June 2024.

SIGNED:

ATTEST:

\_\_\_\_\_  
Chas Jones, Mayor

\_\_\_\_\_  
Ruth Post, MMC, City Recorder



## Philomath City Council Agenda Item Summary

---

Title/Topic: Public Hearing on and consideration of Resolution 24-17 Adopting the Budget and Making Appropriations for the 2024-25 Fiscal Year.

---

Meeting Date: June 10, 2024  
Department: Finance

Staff Contact: Mike Murzynsky  
Email: [mike.murzynsky@philomathoregon.gov](mailto:mike.murzynsky@philomathoregon.gov)

---

### ISSUE STATEMENT

The purpose of this resolution is to consider Resolution No. 24-17 regarding the possible adoption of City of Philomath 2024-2025 Fiscal Year budget and make appropriations.

Staff recommends the adoption of Resolution No. 24-17.

### BACKGROUND AND FISCAL NOTES

The Budget Committee has approved the City Budget for Fiscal Year 2024-25 on May 22, 2024, for the City Council's adoption. Resolution 24-17 provides for budgeted appropriations of \$36,105,970 and ending fund balance (UEFB) \$4,735,548 for total requirements of \$40,841,158.

The City Council can decrease the expenditures in any fund or the Council increase expenditures in any fund up to \$5,000 or 10%, whichever is greater. To keep the budget balanced, an offsetting increase or decrease in fund allocation or revenue must accompany any change made.

Fiscal Notes: The budget provides a continuation of existing types of expenditures, included in the budget is funding for City personnel within the various departments, material and services to operate City functions, capital projects and City debt service payments. The City has reallocated personnel within the budgets. Finally, the budget continues to provide a commitment for reinvestment in the City's water, wastewater, and stormwater infrastructure.

### COUNCIL OPTIONS

1. Approve Resolution 24-17 as presented.
2. Approve and Amend Resolution 24-17.

### RECOMMENDED MOTION

I move to adopt Resolution No. 24-17, a resolution adopting Fiscal Year 2024-2025 budget as recommended by the Budget Committee, for budget appropriations of \$36,105,970, and total ending fund balances of \$4,735,548, for total requirements of \$40,841,158.

### ATTACHMENTS

Resolution 24-17

A RESOLUTION ADOPTING THE FISCAL YEAR 2024-2025 BUDGET  
AND MAKING APPROPRIATIONS

THE CITY OF PHILOMATH RESOLVES THAT the budget for Fiscal Year 2024-2025 be adopted in the sum \$40,841,158; this budget is available for review now at City Hall.

THE CITY OF PHILOMATH FURTHER RESOLVES that the amounts for the fiscal year beginning July 1, 2024, and for the purposes shown below are hereby appropriated as follows:

<u>Fund</u>	<u>Adopted Budget</u>	<u>Fund</u>	<u>Adopted Budget</u>
<b>10-General Fund</b>		<b>43-SDC Proprietary</b>	
City Administration	1,960,985	Materials & Services	-
Police	1,911,105	Capital Outlay	2,094,078
Building & Grounds	216,808	Transfer to Sewer	265,000
Parks	264,622	Contingency	490,000
Non-departmental	-	Total	<u>2,849,078</u>
City Council	234,048		
Transfer to Land, Building & Equipment (LBE)	244,057	<b>51- Water</b>	
Transfer to Street	65,721	Operations	1,215,147
		Transfer to LBE	289,084
Contingency	250,000	Contingency	145,000
Total	<u>5,147,346</u>	Total	<u>1,649,231</u>
<b>16-Development Review</b>		<b>52-Wastewater</b>	
Administration	150,000	Operations	1,020,726
Contingency	-	Debt Service	431,000
Total	<u>150,000</u>	Transfer to LBE	537,556
		Contingency	120,000
		Total	<u>2,109,282</u>
<b>21-Street</b>			
Street Operations	781,989	<b>53-Storm Drain</b>	
Transfer to LBE Equipment	70,577	Operations	97,808
Transfer to LBE Equipment	225,000	Transfer out	90,000
Contingency	100,000	Contingency	10,000
Total	<u>1,177,566</u>	Total	<u>197,808</u>
<b>22-Community Development</b>		<b>Total Appropriations</b>	<u>36,105,970</u>
Community Development	30,000		
Contingency	10,000		
Total	<u>40,000</u>		

<u>Fund</u>	<u>Adopted Budget</u>	<u>Fund</u>	<u>Adopted Budget</u>
<b>32-Economic Development</b>		<b>Non-Appropriated Budget Requirement</b>	
Economic Development	46,434	UEFB - General Fund	1,304,411
Contingency	-	UEFB - Development Review	4,900
Total	<u>46,434</u>	UEFB - Street Fund	115,558
<b>41-Land, Building &amp; Equipment</b>		UEFB - Community Development	119,329
Capital Outlay	19,865,685	UEFB - Economic Development	13,830
Contingency	873,540	UEFB - SDC Governmental	1,174,374
Total	<u>20,739,225</u>	UEFB - SDC Proprietary	1,267,228
<b>42-SDC Governmental</b>		UEFB - Water Fund	256,839
Capital Outlay	1,400,000	UEFB - Wastewater fund	455,974
Transfer to LBE Building	-	UEFB - Storm Drain fund	23,106
Contingency	600,000	<b>Total Non-appropriated</b>	<u>4,735,548</u>
Total	<u>2,000,000</u>	<b>TOTAL USES OF FUNDS</b>	<b>40,841,518</b>

Passed and adopted by the City Council of Philomath on June 10, 2024

\_\_\_\_\_  
Chas Jones, Mayor

Attest:

\_\_\_\_\_  
Ruth Post, MMC, City Recorder



## CITY OF PHILOMATH RESOLUTION 24-13

### A RESOLUTION PROCLAIMING INCLUSIVITY

**WHEREAS**, the city of Philomath is located within the traditional homelands of the Marys River or Ampinefu Band of Kalapuya. Following the Willamette Valley Treaty of 1855, Kalapuya people were forcibly removed to reservations in Western Oregon. Today, living descendants of these people are part of the Confederated Tribes of Grand Ronde Community of Oregon and the Confederated Tribes of the Siletz Indians. Indigenous people are valued, contributing members of the Philomath community and represent multiple sovereign tribes among Philomath community; and

**WHEREAS**, Philomath strives to be a city based on mutual respect and understanding, a community that welcomes and values all residents, and treats everyone with human dignity and respect; and

**WHEREAS**, the origin of this proclamation and formation of the City's Inclusivity Committee in 2020 were a direct result of a community-led effort encouraging the City to respond to the murder of George Floyd by committing to eliminate all forms of racism wherever it exists within our community and affirming the principle that all Black lives matter; and

**WHEREAS**, all people, regardless of race, caste, ethnicity, nationality, religion, disability, sex, gender expression, gender identity, sexual orientation, marital status, age, or socioeconomic status live and work together within Philomath and bring pride to our community; and

**WHEREAS**, oppression, discrimination, intolerance, bigotry, hostility, fear, intimidation, harassment, and violence threaten the health, safety, and resiliency of our community.

**NOW, THEREFORE, BE IT RESOLVED** by the Common Council of the City of Philomath that this governing body:

1. **RECOGNIZES** that it cannot forget or change the past, but must choose to guide our community towards a more connected future where we share knowledge to learn from past mistakes and become part of a better world for everyone; and
2. **COMMITTS** to the principles, assurances, philosophy, administration and implementation of Civil Rights compliance laid out through the Civil Rights Act of 1964, the Voters' Rights Act of 1965, the Americans with Disabilities Act of 1991, and all other federal and state protections; and
3. **AFFIRMS** that Philomath must be a welcoming city to all regardless of race, caste, ethnicity, nationality, religion, disability, sex, gender expression, gender identity, sexual orientation, marital status, age, or socioeconomic status; and
4. **DENOUNCES** oppression, discrimination, intolerance, bigotry, hostility, intimidation, harassment, and violence against people due to their identity or status; and

5. **COMMITTS** to continually pursue a culture of safety and wellbeing in recognition that all have the right to live their lives with dignity; and
6. **COMMITTS** to examining systemic oppressions within our city, city government, and city leadership while seeking out training opportunities to assist in identifying and eliminating all forms of discrimination within our city; and
7. **COMMITTS** to ensuring that all public plans, policies, programs, services and activities are designed, implemented, evaluated, and delivered in a manner that advances equity, improves quality of life, and reduces disparities.

**BE IT FURTHER RESOLVED** that in recognition of the importance of these commitments, the Philomath City Council shall annually review, update and reaffirm the inclusivity resolution at the first meeting of the City Council each June.

PASSED by the Council this 10th day of June, 2024.

APPROVED by the Mayor this 10th day of June 2024.

SIGNED:

ATTEST:

\_\_\_\_\_  
Chas Jones, Mayor

\_\_\_\_\_  
Ruth Post, MMC, City Recorder

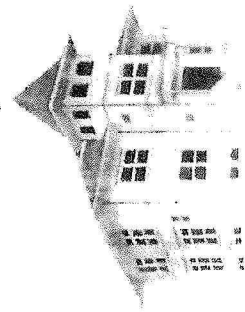

# The College of Philomath Community Project

*“Preserving and Enhancing Our Community”*

---

The goal of our historical restoration efforts is to go  
from This . . .  
back to This . . .

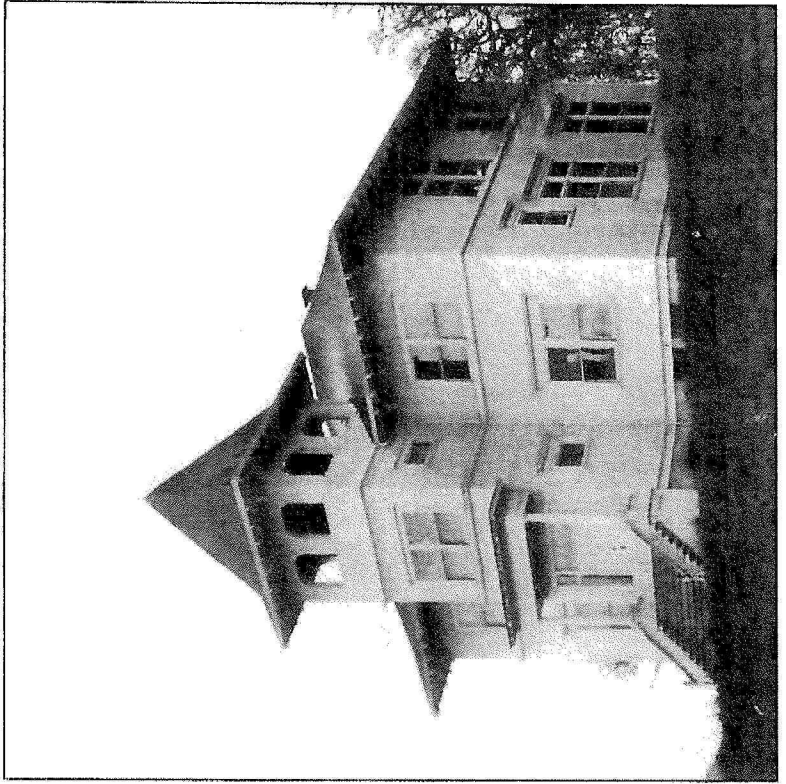
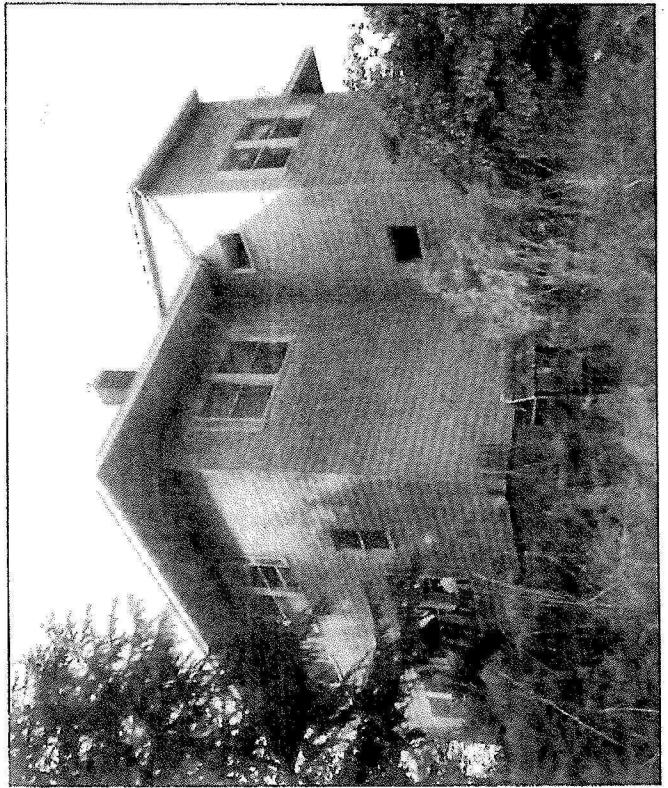

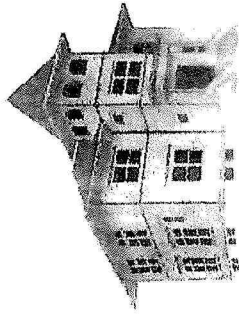

# The College of Philomath Community Project

*“Preserving and Enhancing Our Community”*

---

## *What is CPCC?*

The College of Philomath Community Corporation is a tax-exempt, non-profit organization started by local volunteers.

Our mission:

- To renovate the College of Philomath building in a historically sensitive way that preserves the building’s historic charm.
- To create a comfortable and vibrant community center that focuses on social and cultural programming for seniors.
- To provide space for a non-profit preschool and promote intergenerational interactions between children and seniors.

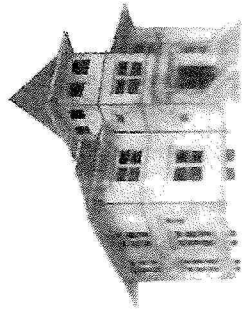

# The College of Philomath Community Project

*“Preserving and Enhancing Our Community”*

---

What is the historical importance of the College of Philomath?

The settlers who founded our town in 1865 had a vision of building a college. They named the new town “Philomath,” for “love of learning,” and sold lots to raise money. Philomath College opened in 1867—a year before OSU was established.

A doctrinal split in the 1880s led to the creation of a competing college, the College of Philomath . . . and the demise of both. The tale of the two colleges is both a compelling story, and an important part of Philomath’s history.

The College of Philomath has played many significant roles in the City’s history: as a college, music conservatory, elementary school, and apartment building.

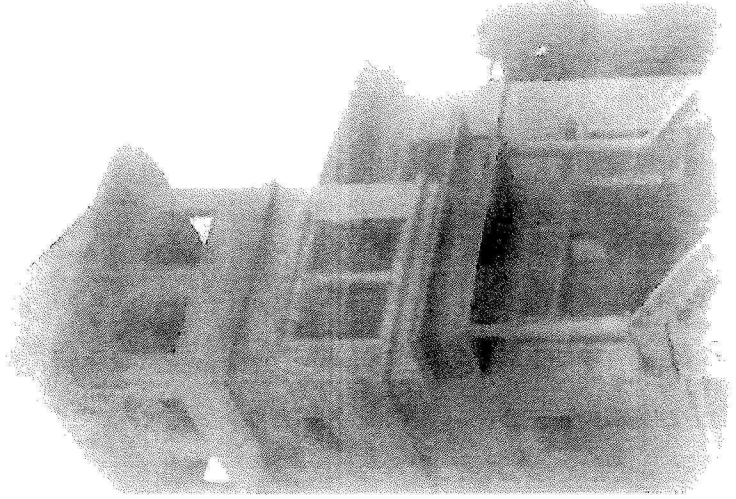

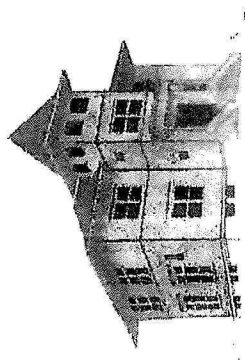

# The College of Philomath Community Project

*“Preserving and Enhancing Our Community”*

---

*Many project partners and collaborators are working together  
to make this project a success, including:*

- Philomath Area Senior Citizens Association (PASCA)
- Retired and Senior Volunteer Program (RSVP)
- Ford Institute Leadership Program (FILP)
- Philomath High School Forestry Club
- Linn-Benton Community College
- Philomath Montessori School
- Philomath Family Medicine
- City of Philomath

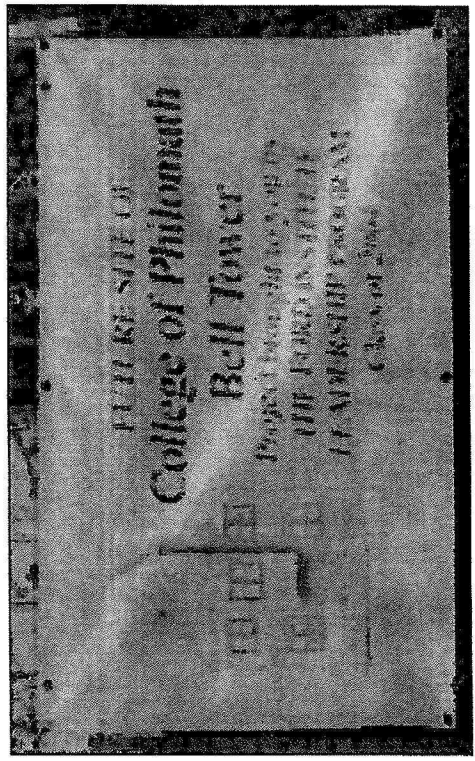

# The College of Philomath Community Project

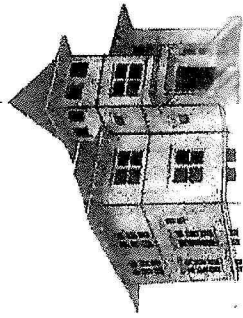

*“Preserving and Enhancing Our Community”*

*At the beginning of this project, volunteers from CPCC and PASCA teamed with RSVP and the City of Philomath to survey interest in services for seniors.*



# The College of Philomath Community Project

*“Preserving and Enhancing Our Community”*

*The response from seniors in Philomath and western Benton County exceeded expectations.*

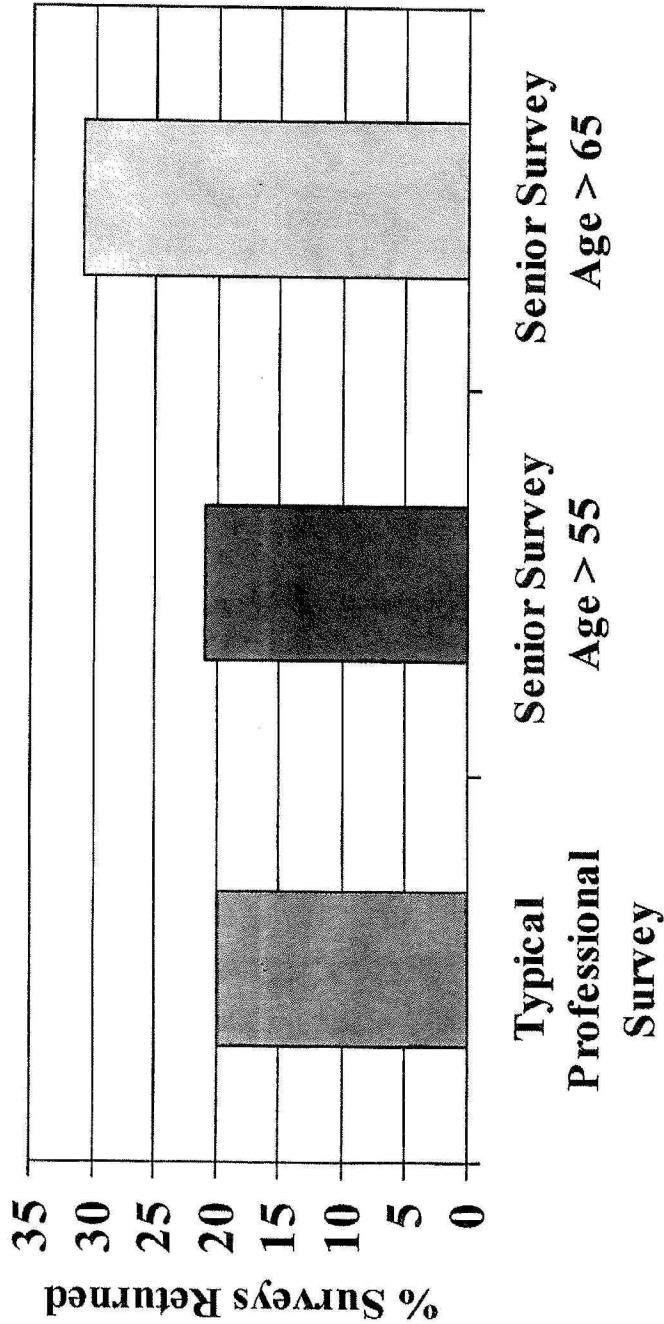



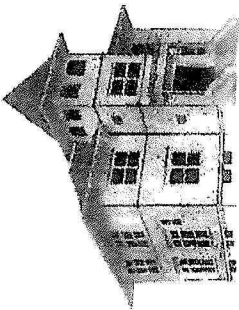

# The College of Philomath Community Project

*"Preserving and Enhancing Our Community"*

*We learned seniors have many needs and interests,  
but mainly they want to have fun!*

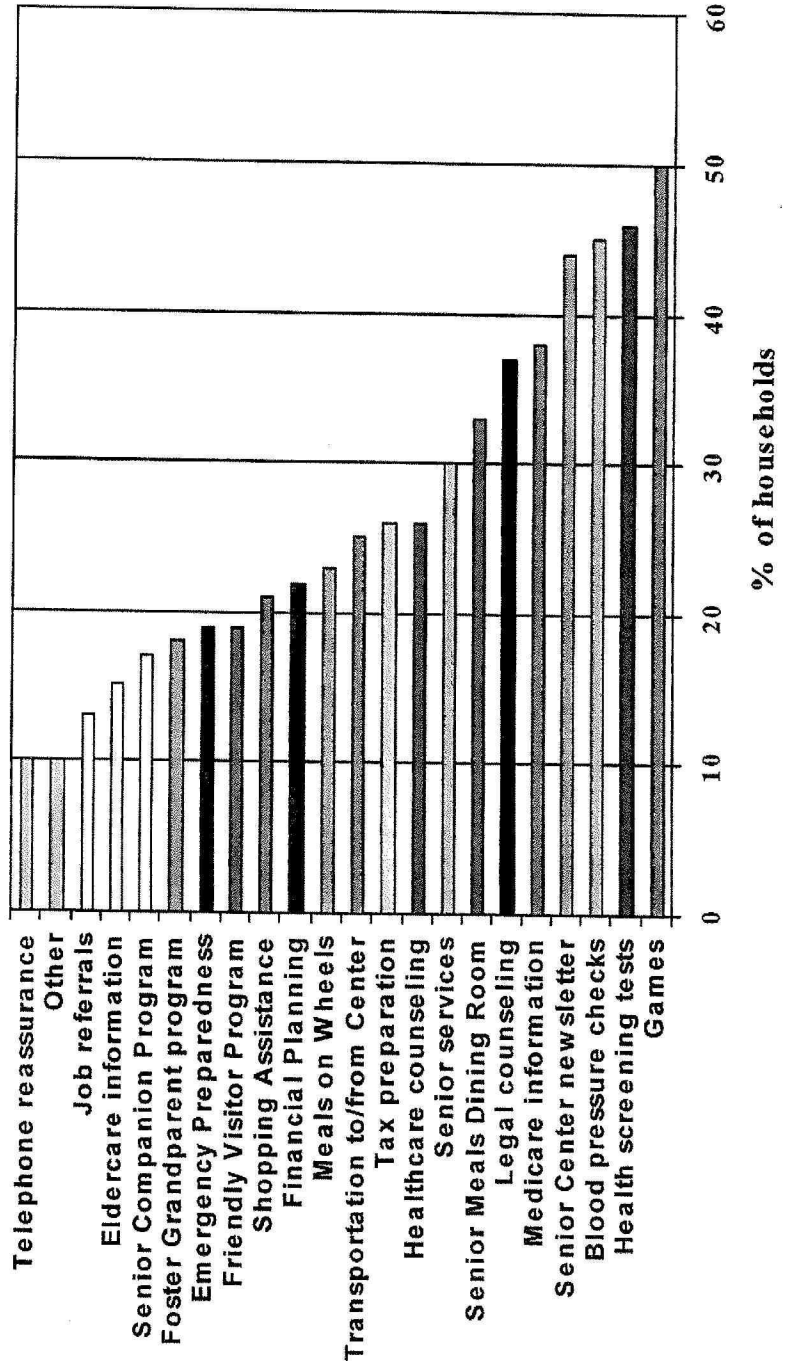

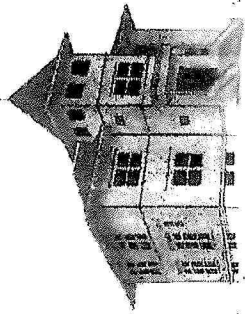

# The College of Philomath Community Project

*“Preserving and Enhancing Our Community”*

*We learned seniors also have many ideas  
about how to have fun . . .*

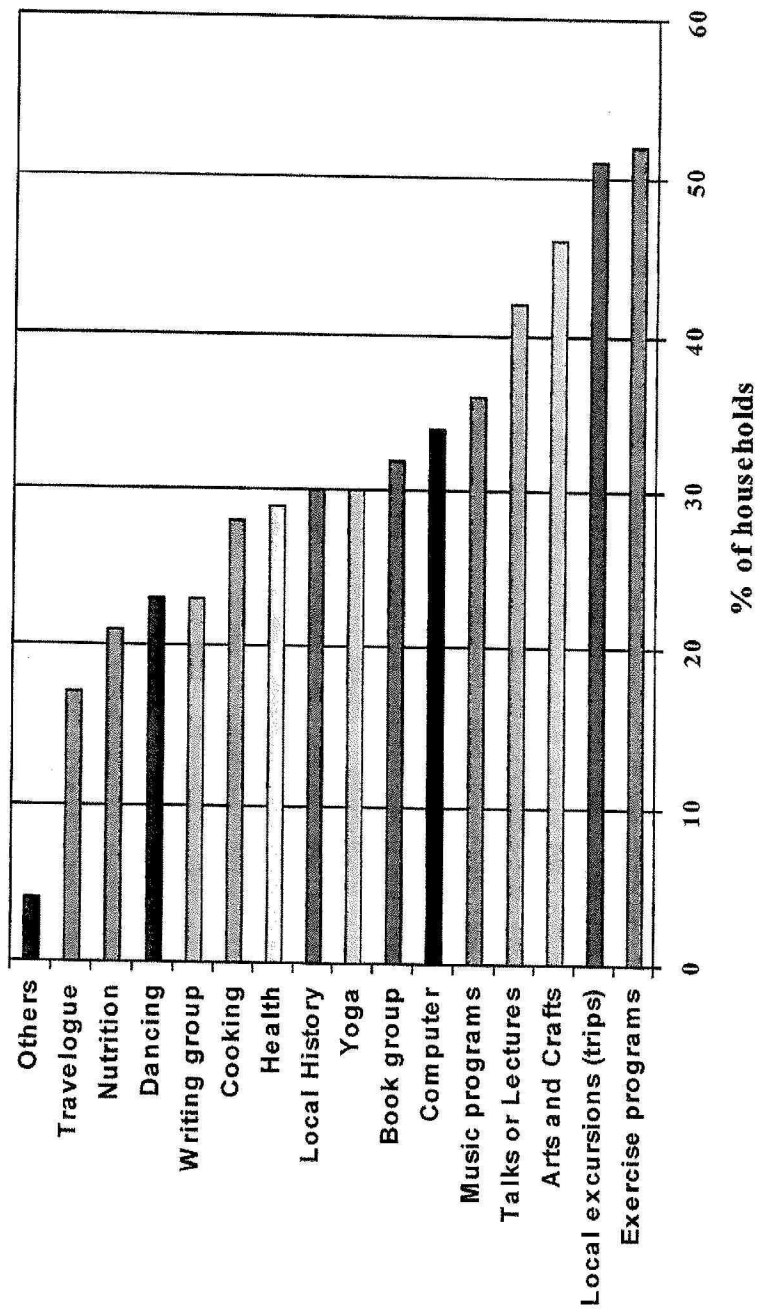

# The College of Philomath Community Project

*“Preserving and Enhancing Our Community”*

*So far, many of our project donors  
have been from the timber industry:*

- Stimson-Miller Foundation
- Starker Forests
- Ralph Hull Foundation
- Hull-Oakes Lumber Company
- Ford Family Foundation
- Ford Institute Leadership Program

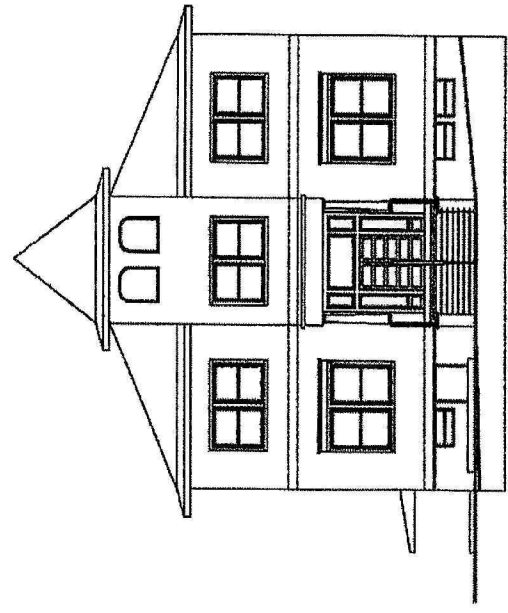
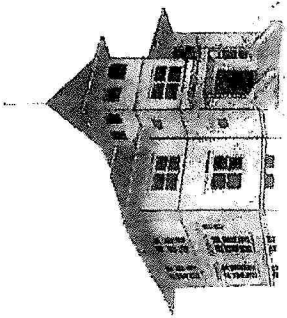

FRONT ENTRANCE  
EAST ELEVATION

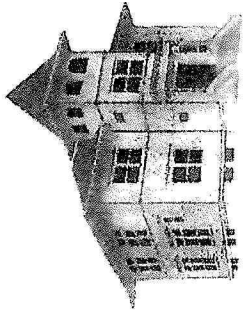

# The College of Philomath Community Project

*“Preserving and Enhancing Our Community”*

*The 27 Philomath participants in the Ford Institute Leadership Program gave us a tremendous boost when they chose to rebuild the missing belltower as their class project.*

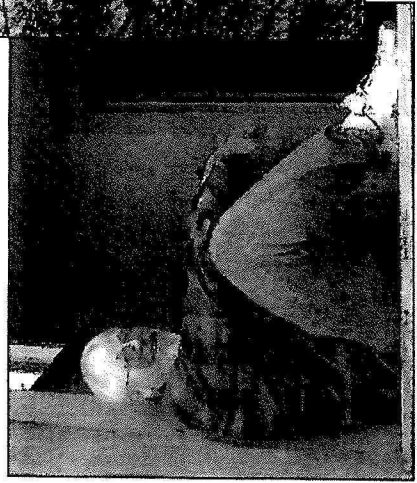
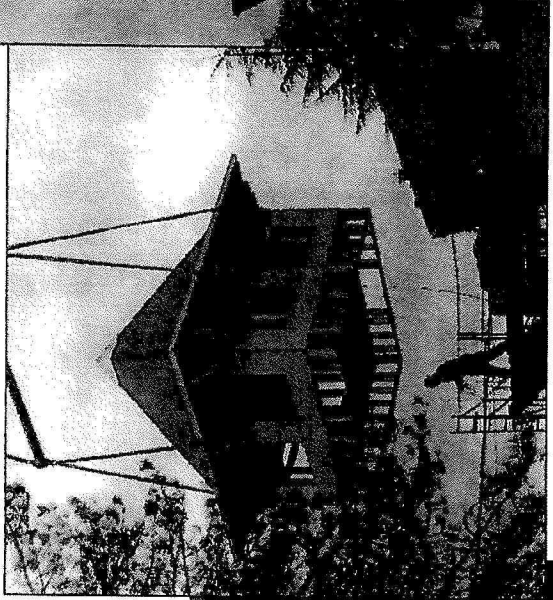
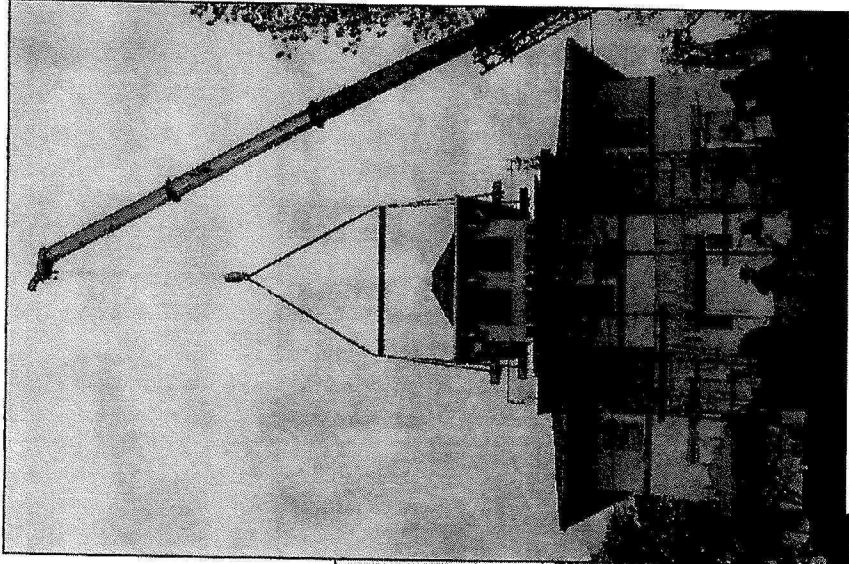

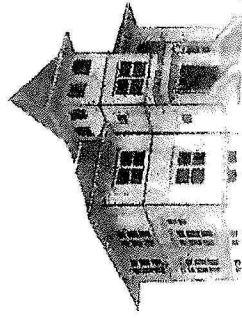

# The College of Philomath Community Project

*“Preserving and Enhancing Our Community”*

---

---

*In summary, we believe this is a “feel good” project that benefits the entire community.*

- It preserves an important historical building, which we are working to have listed in the National Register of Historic Places.
- It may generate increased awareness of Philomath’s unique history.
- It meets the social, cultural, and physical needs of our seniors—including rural seniors, who are most at risk for feelings of isolation and depression.
- It provides space for a non-profit preschool and promotes intergenerational learning and interactions between seniors and young children.
- It has a high probability of success, which increases the probability of success for other community projects.
- Finally, it will serve as a dramatic and visible reminder of what we as a community can accomplish.

## The Historic Importance of the College of Philomath

Built in 1909, the College of Philomath building is inexorably linked with the formation and history of the City of Philomath, serving the community over the years as a college, music conservatory, elementary school, and apartment building.

In 1853, a wagon train of nearly 100 members of the United Brethren Church arrived at the Mary's River Settlement in Benton County, Oregon, with a dream of building a college. They platted the City of Philomath (Greek for "love of learning") in 1865, and sold lots to raise money for the construction of Philomath College. It opened in 1867.

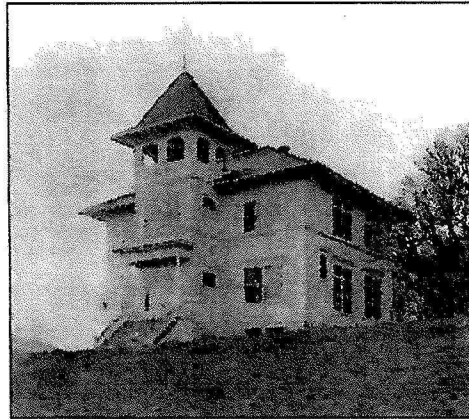

The College of Philomath building, also known as Barkley Hall.

Philomath's second college, the College of Philomath, was founded in 1889. Its existence reflects a doctrinal split, primarily pertaining to freemasonry and membership in secret societies, that created decades of debate within the national United Brethren Church. Nationwide, in 1889, the Church separated into two factions: the "liberals" and the "radicals" or conservatives. Philomath College's faculty and students, as well as other local residents, took sides in the struggle. The national schism had a profound affect on Philomath city life. The Philomath College building was vacated for three years, while the two factions contested ownership of the property.

Philomath College President James Keezel and his wife, faculty member Sarah Keezel, joined with the radical conservatives in breaking away from Philomath College and founding a new college, eventually called the "College of Philomath." The radicals appointed James Keezel as president and held classes off campus during 1889-90. In 1890, the radicals constructed a three-room school building at Pioneer and North 10th streets. The structure was nearing completion when scaffolding collapsed, killing President Keezel. Newly widowed Sarah Keezel, a faculty member of the new college, was asked to assume the presidency of the coeducational institution—an unusual honor for a woman in the 1890s.

In 1892, just as the College of Philomath was gaining momentum, fire destroyed the newly constructed building, which had been named "Keezel Memorial Chapel." A replacement building, "planned after the former" and dedicated as "Keezel Chapel," was ready for classes by late 1892. But the ill-fated College of Philomath suffered yet another blow in 1905, when the second building burned to the ground. The College of Philomath closed for several years, while the Church contemplated the future of the unfortunate institution.

In 1909, the third college building was constructed, thanks to the perseverance of Henry Barkley, a senior bishop in the national United Brethren Church.

However, despite a fresh start in the handsome new building, aptly named "Barkley Hall," the College of Philomath faced increasing financial difficulties and was forced to close its doors forever at the end of the 1912-13 school year.

In 1922, Philomath College bought Barkley Hall from its former rival for use as the Philomath College Conservatory of Music. At the end of the 1928-29 school year, however, the Trustees of Philomath College suspended classes for a year to address the institution's worsening money problems. The stock market crash in the fall of 1929 irrevocably sealed the fate of Philomath College, and it never reopened.

In the 1930s, the Philomath School District, faced with overcrowding, leased Barkley Hall for use as a grade school. Called the "Hill School" because it sits on a hill three blocks north of downtown Philomath, it usually accommodated first through third grades. The older students (fifth through eighth graders) remained at the older grade school, called "West School" (1900), on Main Street. In 1949, students from the Hill School and West School moved into the newly constructed Philomath Elementary School on Applegate Street. Barkley Hall subsequently passed into private ownership in the 1950s.

The Philomath College building is listed in the National Register of Historic Places and serves as the home to the Benton County Historical Museum. Area residents plan to appropriately rehabilitate the College of Philomath's Barkley Hall for use as a senior center, preschool, and community learning center, and apply for its well-deserved placement in the National Register as well.

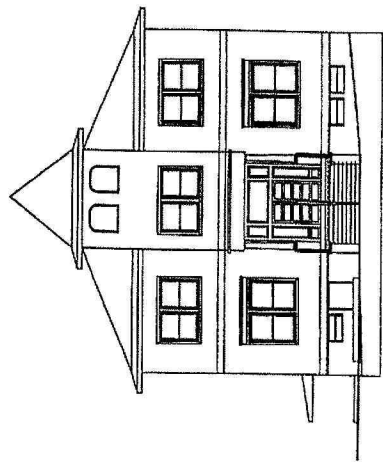

FRONT ENTRANCE  
EAST ELEVATION

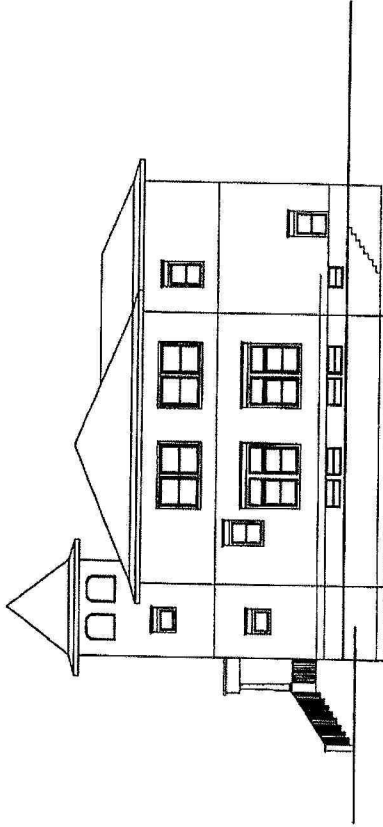

NORTH ELEVATION

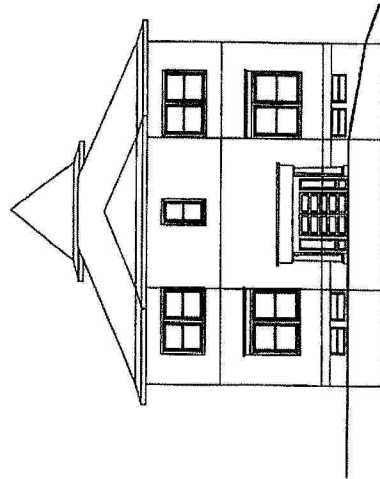

BACK ENTRANCE  
WEST ELEVATION

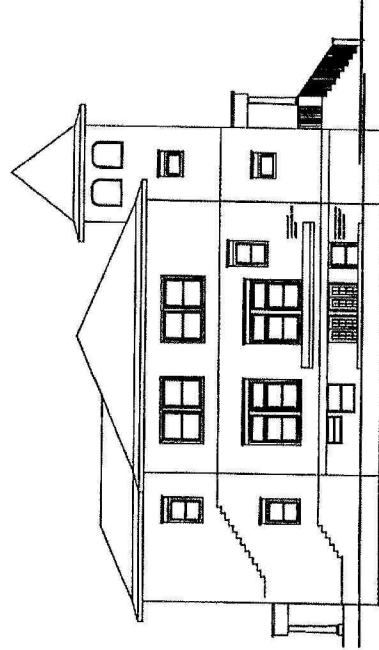

SOUTH ELEVATION

	<p><b>CY STADSFOLD</b> <b>A.J.A. ARCHITECT</b></p> <p>10 SPRINGFIELD COMMERCIAL PHILMATH, PA (610) 753-0152 FAX 610-753-5882</p>	<p><b>SHEET TITLE: ELEVATIONS</b></p> <p>SCALE: 1/8" = 1'-0"</p> <p>DATE: NOVEMBER 4, 2004</p> <p>REV: _____</p> <p>SHEET NO.</p>
	<p>COLLEGE OF PHILOMATH RENOVATION</p>	

**Owner**

COLLEGE OF PHILOMATH  
COMMUNITY CORP. (CPCC)  
P.O. BOX 1033  
PHILOMATH, OR 97370

**Agents**

SCOTT RAMSEY  
SHA SIFFORD

**Project Summary**

2 STORY WITH BASEMENT. UPPER FLOORS FINISHED FOR SENIOR CENTER. BASEMENT SHELL ONLY.

**Area Summary - Square Footage**

**SITE**

<b>SITE</b>	21,843	1.00	0.501 Acres
<b>Building Footprint</b>	2,533	0.12	
<b>Parking/Drive</b>	12,600	0.58	
<b>Sidewalk/Entries</b>	600	0.03	
<b>Pedestrian/Landscape</b>	6,110	0.28	

BUILDING FLOOR AREAS	BASEMENT GROSS AREA, sf	MAIN FLOOR GROSS AREA, sf	UPPER FLOOR GROSS AREA, sf	TOTAL
<b>EXISTING</b>	1,978	2,118	2,118	6,214
<b>ADDITION</b>	415	415	415	1,245
<b>TOTAL</b>	<b>2,393</b>	<b>2,533</b>	<b>2,533</b>	<b>7,459</b>

COST ASSIGNMENT CSC PHASES	CONSTRUCTION SUBTOTAL	CONSTRUCTION SUBTOTAL WITH MARKUPS	PHASE 1 - SENIOR CENTER	PHASE 2 - BASEMENT	TOTAL \$
<b>AREA, SF PORTION</b>			5,068 0.68	2,393 0.32	7,461 1.00
<b>CONSTRUCTION COST ASSIGNMENT</b>					
GENERAL REQ'MTS	160,500	227,266	154,854	72,911	227,266
SITE CONSTRUCTION	245,181	347,172	347,172		347,172
ADDITION	264,763	360,739	360,739		360,739
BASEMENT	200,573	284,007		284,007	284,007
MAIN FLOOR	336,805	476,909	476,909		476,909
UPPER FLOOR	195,967	277,471	277,471		277,471
ROOF	63,040	75,103	75,103		75,103
<b>TOTAL CONSTRUCTION</b>	<b>1,446,818</b>	<b>2,048,665</b>	<b>1,691,747</b>	<b>356,918</b>	<b>2,048,665</b>
<b>PROPERTY COST</b>					
ORIGINAL PROPERTY PURCHASE					220,000
WEST PROPERTY PURCHASE					150,000
<b>OTHER COSTS</b>					
BELL TOWER RECONSTRUCTION					65,000
PROJECT ADMINISTRATION - CSC					75,000
TENANT RELOCATION					20,000
<b>TOTAL PROJECT</b>	<b>1,446,818</b>	<b>2,048,665</b>	<b>1,691,747</b>	<b>356,918</b>	<b>2,596,585</b>

## Bell tower crowns College of Philomath

*Project teaches volunteers the benefits of compromise, collaboration*

BY REBECCA BARNETT  
CORVALLIS GAZETTE-TIMES

The future site of the College of Philomath bell tower became a reality at 10 a.m. Saturday, as a crane hoisted a year's work into place atop the 59-year-old building.

The project of 25 community volunteers involved planning, compromise, fund raising and hundreds of hours of labor. It showed the people involved how they accomplish together more than they could as individuals.

While rehabilitation of the historic building that will be the future senior center and home of the Philomath Montessori School will continue, the people involved with the bell tower project are talking about what they'll do next to make Philomath a better place to live.

"I really think that cooperation is the way things like this get done, through philanthropy and volunteer labor," said Ed Hurff, a retired middle school teacher and a member of the Ford Family Foundation's first Philomath community leadership class.

The group was formed a year ago, and the first task was picking a project they could ac-

complish in a year.

Hurff said he was interested all along in the bell tower project. Others in the group had different ideas. Reaching consensus wasn't always easy, and there were many doubts and obstacles they overcame.

"There were a lot of peaks and valleys, but things seemed to work themselves out," Hurff said.

Hurff said he wasn't surprised to be standing beneath the installed bell tower near 16th and Pioneer streets Saturday morning.

Toni Hoyman and Marcy Gregg, also members of the leadership class, said they enjoyed getting to know different people in the community who shared good intentions, if not always a common vision.

Hoyman, a former Philomath City Councillor, said the leadership class has taught people here a better way to work together. At times in the past, people have been divided over issues facing the community, such as the couplet project. The Ford Family Foundation training was a good model to follow, Hoyman said.

"It goes a long way toward mending the schisms that happened around the couplet,"

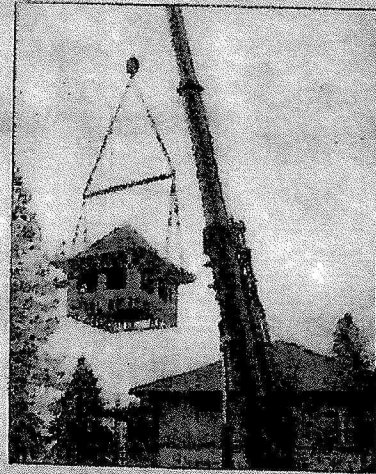

A crane lifts the bell tower into place atop the College of Philomath.

Hoyman said. "It's a good resource to bring about healing and cohesiveness."

While the first leadership class is finishing its training, there will be two more groups of volunteers organized to go through the same course.

The Ford Foundation works with rural communities, such as Philomath, and has invested more than \$750,000 here since 1999. By investing in people and projects, the goal is that they will use their newfound skills to continue to do good things.



PHOTOS CONTRIBUTED BY SCOTT HANLEY

Community volunteers watch Saturday morning as the new bell tower is hoisted into place at the College of Philomath. When finished, the building will house a senior center and the Philomath Montessori School.

**In pursuit**  
 Birte Steven chases her  
 Olympic dream.  
 Sports, B1

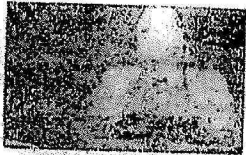

**Explore**  
 Follow the historic  
 Lewis & Clark journey.  
 Community, A2

**Film fight**  
 Hot movies will battle for  
 summer supremacy.  
 Entertainer, inside



CORVALLIS

# Gazette-Times

Your Community ... Your Newspaper

Friday, May 14, 2004

www.gazettetimes.com \$0 cents

## LANDMARK EFFORT

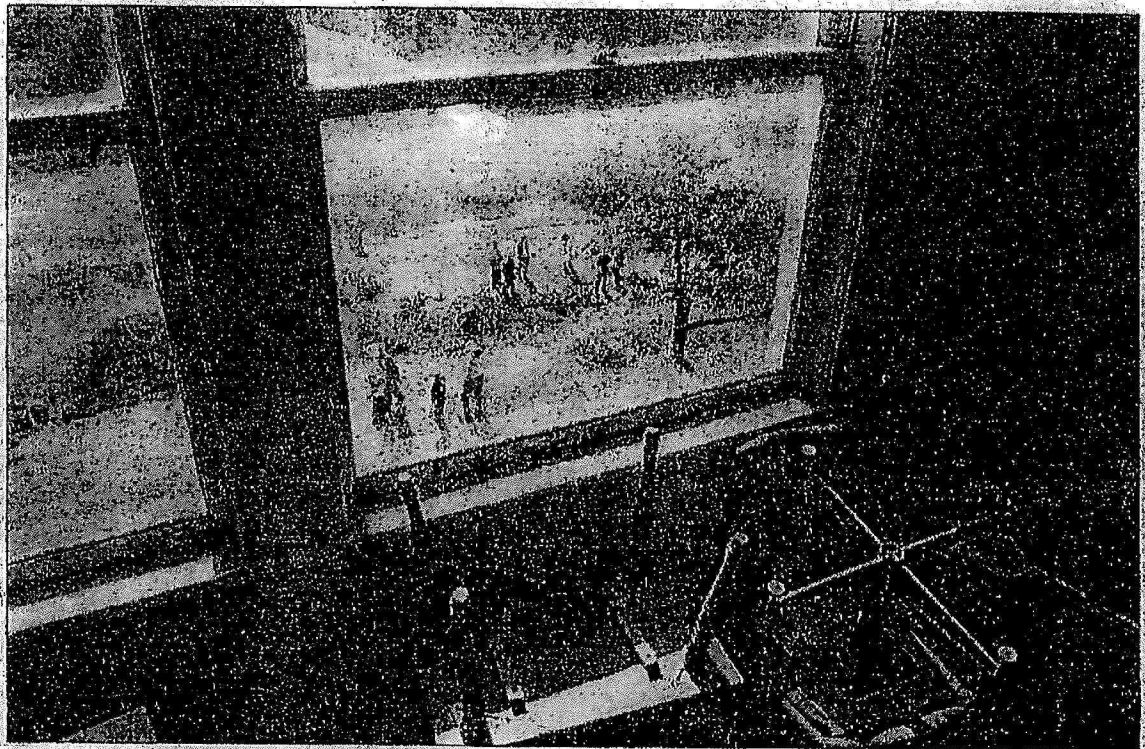

RYAN GARDNER/Gazette-Times

While the Philomath forestry students work at clearing brush and tree limbs away below, old chairs and tables sit in a small room on the second floor of the old College of Philomath building. The site has since been a grange hall, a grade school and is currently an apartment building.



Philomath senior Kelly Riley cuts away some ivy that is choking out a pine tree on the property. 'I volunteered to do this,' she said. 'I like running the chainsaw.'

## A fresh view of an old building

*Forestry students clear sight of former college building*

By KYLE ODEGARD  
 Gazette-Times reporter

PHILOMATH — Chainsaws revved and a wood chipper spit debris Thursday morning at the old College of Philomath site, at the corner of 10th and Pioneer streets.

The structure had been shrouded from view by trees and brush for decades, so long that many locals forgot it was there.

They have a clear view now, thanks to Philomath High School forestry students.

Teens cleared the east side of the property this week and gained some more practical experience through the community service work.

'It's a really good opportunity for us to help out in the community'

See 'View' A11

## ● View: Building

Friday, May 14, 2004, Corvallis Gazette-Times, Corvallis, Ore.



RYAN GARDNER/Gazette-Times

Philomath high school student Matt Burdick weaves his way through the pine tree Thursday morning to attach a rope to the top so the students can direct the fall of the tree.

Continued from front page  
where we can," said forestry teacher Christie Shaw. "The community is very supportive of our program."

Residents plan to transform the College of Philomath building into a much-needed senior center, Montessori school and non-profit offices.

Though Philomath has 4,000 residents, it doesn't have a senior center, and older residents go to Corvallis' center for public services and to socialize.

Making the building more visible might help people imagine what the facility could be like. And that could lead to more donations to renovate the structure.

About \$1.25 million is needed for the College of Philomath Senior Center Project, said chairman and City Council member Scott Ramsey.

Donations are starting to roll in, Ramsey said, including \$40,000 in pledges and an additional \$50,000 of in-kind work.

This week's work by the high schoolers was worth about \$3,500, said project secretary Meredith Howell.

"I can't wait to get started on the construction part of it, but that's a long ways off," Ramsey said.

A few moments later, he was starting up a chainsaw again.

Nearby, PHS senior Matt Burdick scaled an unhealthy pine tree, digging his spurs, or spikes, into the trunk and dragging a rope up with him.

About 50 feet up, he looped the rope around the tree and then scrambled down.

"Usually, if there's any climbing jobs, I'm the one doing it," Burdick said, casually.

For the 20 students, felling trees and such was no big deal. They've done it

before. "This one is volunteer (work), which is cool," Burdick added.

Last weekend, PHS forestry students placed second in a state logging competition at Peavy Arboretum. Teens from the program also have cleared downed trees from this winter's snowstorms. Cut wood from its volunteer projects is donated to the Philomath Cleaners.

Thursday morning, when a student cut down the pine tree, about 15 classmates pulled on the rope to direct its descent. It landed in the building's gravel parking lot with a crunch and a cloud of dust.

The College of Philomath was created in 1890 after a rift occurred within Philomath College.

It was built on higher ground than its rival — founders probably would say both literally and metaphorically. It used to be visible from Main Street, but trees grew to hide it from view and its bell tower was removed.

In the 1930s, the building served Philomath elementary students as the "Hill School." One high schooler said his father attended school there.

Since the 1950s, the College of Philomath building has been a small apartment complex. Philomath College now houses the Benton County Historical Museum.

Next week, the College of Philomath Senior Center project expects to gain ownership of the property and building. Rent from apartment tenants will cover mortgage payments and insurance, Howell said.

To volunteer for the College of Philomath Restoration Project, call Scott Ramsey at 929-2909.

Kyle Odsgard covers Philomath and rural Benton County. He can be contacted at [kyle.odsgard@lee.net](mailto:kyle.odsgard@lee.net) or 758-9523.



Members of the Ford Institute leadership development class in Philomath chose to rebuild the College of Philomath's bell tower for their class project.

# Bell tower restored by

**Tower restoration increases visibility of the College of Philomath transformation project**

The College of Philomath building, built in 1909, has served the community over the years as a college, music conservatory, elementary school and apartment building.

A new initiative by local volunteers, the College of Philomath Community Corporation, will transform the historic building into an urgently needed community center containing space for a senior center, nonprofit preschool, cultural venue, continuing education classrooms and community meeting space.

Their efforts were given a public boost when members of the Ford Institute leadership development class in Philomath chose to rebuild the College of Philomath's bell tower for their class project.

"The bell tower is the first step in the much bigger project," says leadership class member Sha Sifford. "We felt it would raise the visibility of the project throughout the community and get a lot of people

interested who wouldn't otherwise have been involved."

The leadership group took on the project in two steps: planning and fund-raising, and then construction. During the first phase, class members

**We did a lot of things wrong, but the one thing we really did right was network with other groups**

—Sha Sifford

met with the project architect, obtained a construction permit, hired a contractor, prepared the base of the bell tower structure to accept a new tower, and installed scaffolding around the bell tower's base.

Class volunteers also launched a very successful fund-raising campaign, raising more than \$40,000 in cash donations as well as in-kind donations of labor and materials valued at nearly \$30,000.

### Phase 2

During the second phase, the bell tower was built on the ground and, in an exciting "topping off" ceremony, a 190-ton crane lifted the new bell tower into position. A small derrick was then built between the bell tower and the building.

Only the finish work re-

## Networking helped the group discover hidden human talents in the community.

ended up bringing in other people who weren't part of the Ford group," Sifford says. "It's one of those things where you tell a friend about it, they tell someone else, who gives you a phone call and pretty soon you have people like Curtis Johnson, a retired biophysicist, working with you."

Johnson, a woodworking specialist who retired from OSU's Department of Biochemistry and Biophysics, volunteered to precisely replicate the bell tower's 11 decorative

corbels (or brackets), which had been hidden above the aluminum soffits (the underside of the roof overhang) installed in the mid-1970s.

### Hidden talents

The group also discovered hidden talents among their own. For example, class member Ed Hurff, a retired science teacher and woodworker, volunteered to build custom window casings to match the curve of the bell tower's window openings.

"People get to step outside their usual roles and routines," Sifford says. "The treasurer for our project is Ken Elver, the local police chief and a really great guy. It's fun for people to get involved in projects that are kind of outside what they do every day, and work with people they ordinarily wouldn't even meet." ■

## Class takes on other projects

Members of the Philomath Ford Institute Leadership Program have lent their expertise and training to several projects in addition to the bell tower.

In Wren, volunteers, including Leadership Program members, are hard at work raising funds to refurbish a community center that has fallen into disrepair. Group members hope to renovate the kitchen and replace the outhouse with modern bathrooms.

In Summit, a badly needed well and pump shed has made the Summit Community Center much more usable. "Because I took the class, I was aware of Ford's interest in small rural communities helping themselves and giving them a hand up," says Jeanette Fair, a member of the 2004 Philomath class who is also active in Summit Community Educational Outreach, the nonprofit group that maintains the center.

Fair transferred the expertise she gained helping write grants for the group's bell tower project to the community center.

She wrote a grant request to The Ford Family Foundation for \$4,500 to pay for drilling of a well, a pressure pump and an equipment closet to be built on the outside of the building. "We submitted the grant in July, it was approved in September, and we had the well drilled the next week," Fair says. ■

# class volunteers

mains, custom-cut glass installed in the casings, historically appropriate cedar shingle siding installed on the bell tower's exterior, and painting of the siding and exterior trim.

The project resulted in some valuable lessons for class members, many of whom had never been involved in such a big project. "We did a lot of things wrong, but the one thing we really did right was network with other groups," Sifford says.

Networking helped the group discover hidden human talents in the community. "We



Ed Hurff lends his skills to the bell tower project. Ford Institute Leadership Program volunteers not only pounded nails, they launched a successful fund-raising campaign.



REVISIONS	BY

**A BASEMENT LATERAL FORCE RESISTING SYSTEM UPGRADE**  
**310 N 10th ST**  
**PHILMATH, OR**  
**BASEMENT SOUTH AND WEST INTERIOR ALL ELEVATIONS**

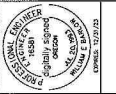

**CIVIL ENGINEERING DESIGN**  
 WILLIAM E. BARLOW, P.E.  
 P.O. BOX 43  
 PHILMATH, OR 97370  
 541-659-8777  
 www.civildesign.com

DATE: 4.4.2023  
 DRAWN: MEB  
 SHEET:

**S4.1**

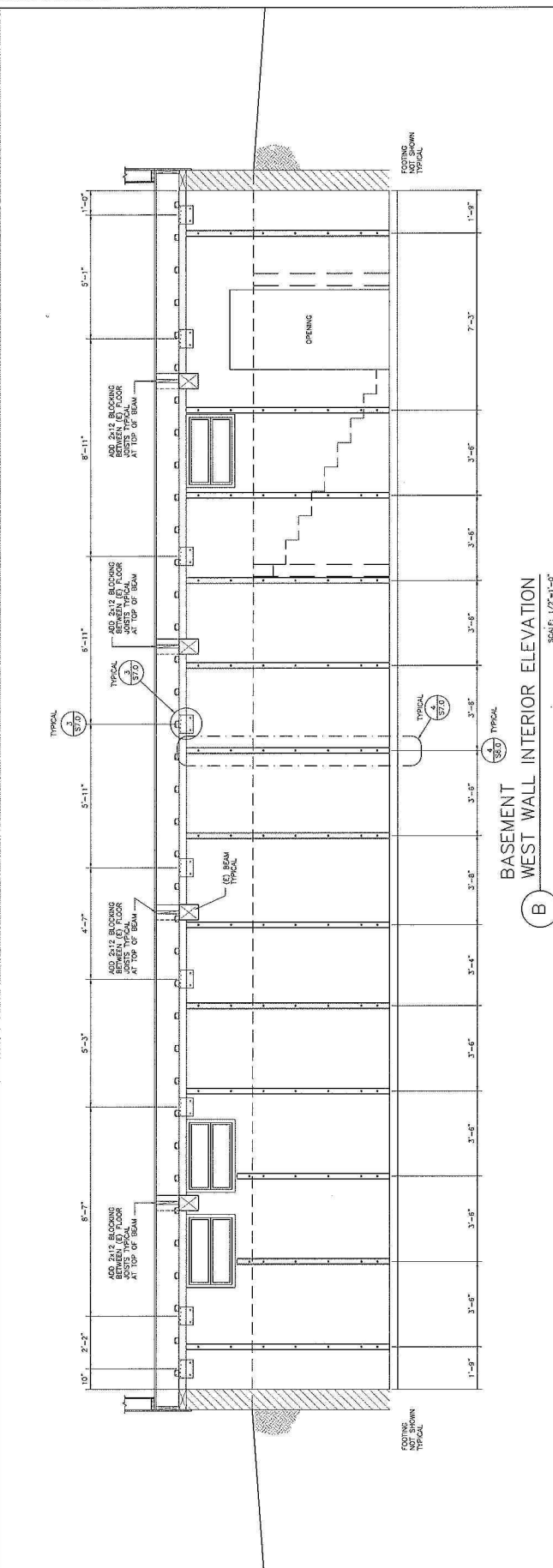

**B**  
**BASEMENT WEST WALL INTERIOR ELEVATION**  
 SCALE: 1/2"=1'-0"

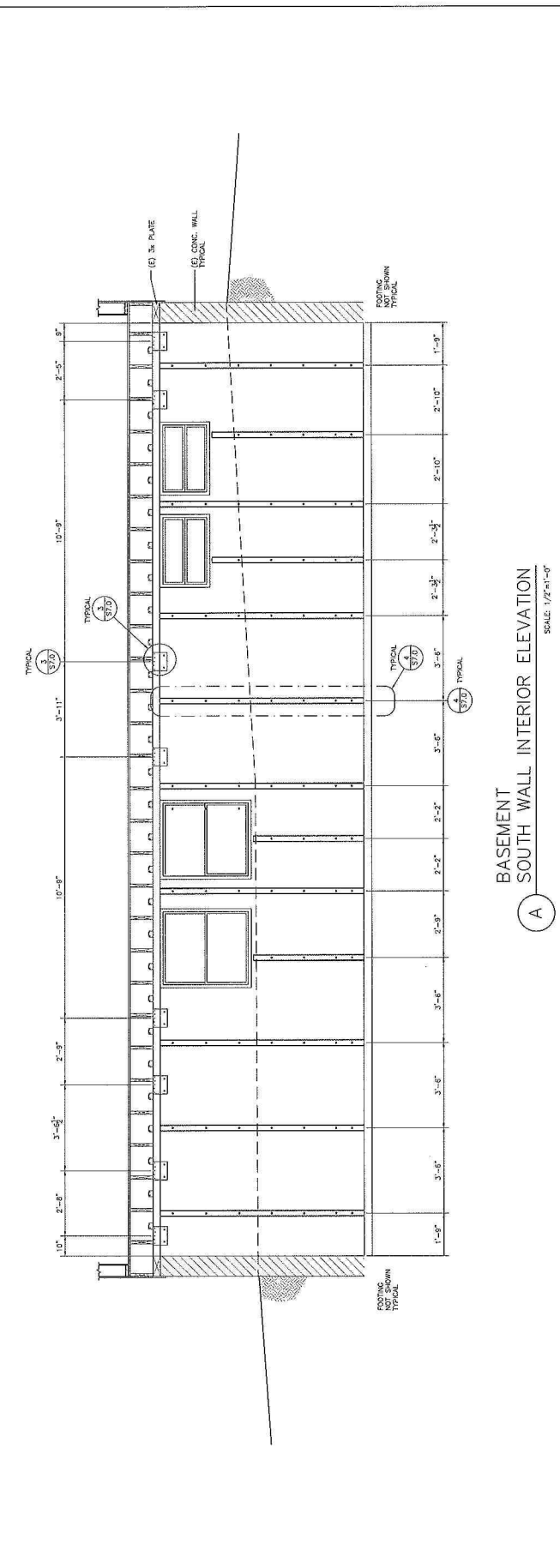

**A**  
**BASEMENT SOUTH WALL INTERIOR ELEVATION**  
 SCALE: 1/2"=1'-0"

REVISIONS	BY

**A BASEMENT LATERAL FORCE RESISTING SYSTEM UPGRADE**  
 310 N 10th ST  
 PHILMATH, OR

**BELL TOWER BASEMENT INTERIOR WALL ELEVATIONS**

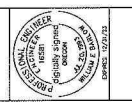

**CIVIL ENGINEERING DESIGN**  
 WILLIAM E. BARLOW, P.E.  
 P.O. BOX 43  
 PHILMATH, OR 97370  
 541.609.8177  
 www.civildesign.com

DATE: 4.4.2023  
 DRAWN: MEB  
 SHEET: **S5.0**

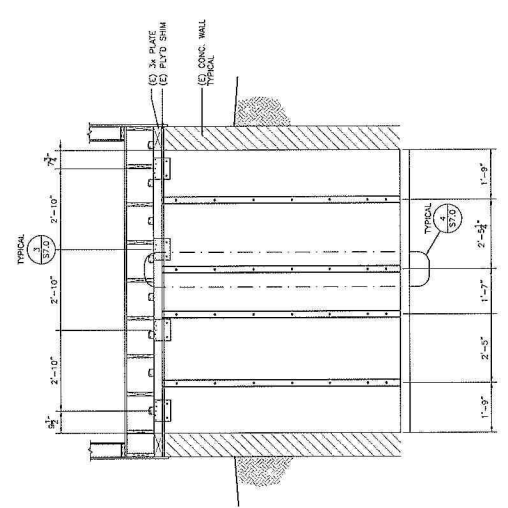

**BELL TOWER BASEMENT NORTH WALL ELEVATION**  
 SCALE: 1/8"=1'-0"

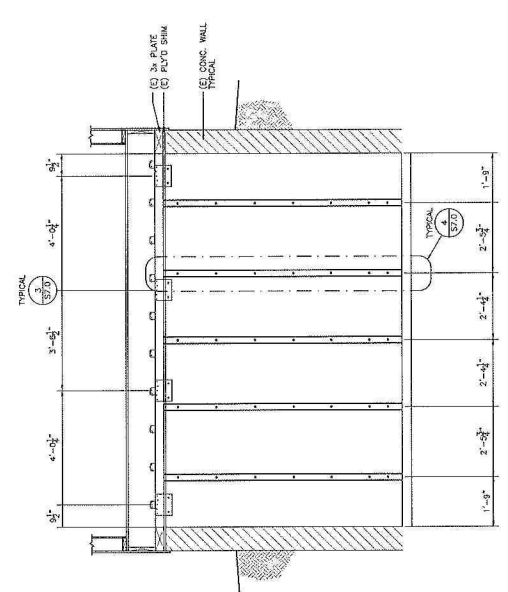

**BELL TOWER BASEMENT EAST WALL ELEVATION**  
 SCALE: 1/8"=1'-0"

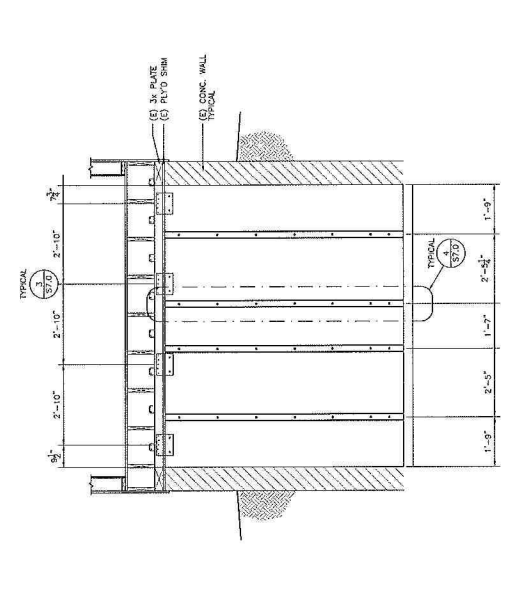

**BELL TOWER BASEMENT SOUTH WALL ELEVATION**  
 SCALE: 1/8"=1'-0"

1  
2  
3  
4  
5  
6  
7  
8  
9  
10  
11  
12  
13  
14  
15  
16  
17  
18  
19  
20  
21  
22  
23  
24  
25  
26  
27  
28  
29  
30  
31  
32  
33  
34  
35  
36  
37  
38  
39  
40  
41  
42  
43  
44  
45  
46  
47  
48

**PHILOMATH CITY COUNCIL  
WORK SESSION NOTES  
Philomath City Hall Council Chambers  
May 13, 2024**

**A. CALL TO ORDER - ROLL CALL**

Work session called to order at 5:30 p.m. by Council President Ruth Causey.

**Present:**

Council President Ruth Causey  
Councilor Jessica Andrade  
Councilor Diane Crocker  
Councilor Matt Lehman  
Councilor Christopher McMorran  
Councilor Teresa Nielson

**Absent:**

Mayor Chas Jones

**Staff Present:**

City Manager Chris Workman  
City Recorder Ruth Post

**Guest:**

Riley Fritsch, IDRAH

**B. WORK SESSION**

Start Time: 5:30 p.m.

1. Government Subsidized Workforce Housing
  - Riley Fritsch described new state housing funding opportunities and non-profit housing strategy he is developing leveraging new state funding assistance programs.
  - Potential for city-owned lot for an affordable housing project.
  - Combination of a day care center with affordable housing described.
  - Discussion about estimated project costs.
  - State-approved modular construction option described.
  - Discussion about modular construction discussed.
  - Housing Needs Analysis recommendations for types of apartments needed discussed.
  - Average Median Income requirements for eligibility discussed.
  - Property ownership and taxation described.
  - Future ownership interest requirements for state program described.
  - New State Administrative Rules restricting requirements for on-site parking described.
  - Management costs associated with affordable housing described.
  - Neighborhood dynamics of locating a project discussed.
  - Concerns about lack of parking discussed.
  - Energy efficiency and environmental friendly construction constraints questioned.
  - Request for ADA accessible units.
  - Prospective next steps described.
  - Unit storage capabilities discussed.
  - Housing Needs Analysis need for multiple types of housing described.
  - Next steps to examine concerns expressed and consult with City Attorney described by City Manager Workman.

- 1       • Feedback received on proposal from Housing & Economic Development Committee  
2       described.  
3

4   **C. ADJOURNMENT**

- 5       1. Work session adjourned at 6:54 p.m.  
6

7       Recorded by Ruth Post, MMC, City Recorder

PHILOMATH CITY COUNCIL  
MEETING MINUTES  
Philomath City Hall Council Chambers  
May 13, 2024

1  
2  
3  
4  
5  
6  
7  
8  
9  
10  
11  
12  
13  
14  
15  
16  
17  
18  
19  
20  
21  
22  
23  
24  
25  
26  
27  
28  
29  
30  
31  
32  
33  
34  
35  
36  
37  
38  
39  
40  
41  
42  
43  
44  
45  
46  
47  
48  
49

**A. CALL TO ORDER - ROLL CALL**

Meeting called to order at 7:02 p.m. by Council President Ruth Causey.

**Present:**

- Council President Ruth Causey
- Councilor Jessica Andrade
- Councilor Diane Crocker
- Councilor Matt Lehman
- Councilor Christopher McMorran
- Councilor Teresa Nielson

**Absent:**

- Mayor Chas Jones

**Staff Present:**

- City Manager Chris Workman
- Public Works Director Kevin Fear
- City Recorder Ruth Post

**B. RECOGNITION**

1. Lige Weedman, Public Works, 10-year anniversary  
Start Time: 7:02 p.m.
  - Council President Causey presented 10-year certificate to Lige Weedman.

**C. PUBLIC COMMENTS**

- Start Time: 7:04 p.m.
1. None.

**D. CONSENT AGENDA**

- Start Time: 7:04 p.m.
1. Minutes of April 8, 2024 City Council meeting.
  2. Minutes of April 22, 2024 City Council meeting.
  3. OLCC Annual Liquor License Renewals

Action: To approve the Consent Agenda as presented.  
 Motion/Second: Councilor Lehman/Councilor Andrade  
 Vote: Action APPROVED 6-0 (Yes: Andrade, Causey, Crocker, Lehman, McMorran, and Nielson; No: None).

**E. NEW BUSINESS**

1. Engineer of Record contract award.  
Start Time: 7:05 p.m.
  - Public Works Director Fear reviewed the request for services process for designating an engineer of record.
  - After review of the scoring, staff recommended having a backup engineer of record available.
  - Questions about pricing for services to be addressed during Council review of an agreement.

- Discussion about the need for a secondary engineering firm if Westech is unable to manage a request for services.
- Specialized services discussed.
- Discussion about the criteria development and evaluation.
- Contract duration of five years with up to two five-year renewals described.

Action: To approve the recommendation of retaining Westech Engineering as the Engineer of Record and Keller Associates as support engineer and direct staff to prepare contracts and bring them back to Council at a future meeting.

Motion/Second: Councilor Nielson/Councilor Lehman

Vote: Action APPROVED 6-0 (Yes: Andrade, Causey, Crocker, Lehman, McMorran, and Nielson; No: None).

## **F. ORDINANCES & RESOLUTIONS**

1. Resolution 24-11 Authorizing application for Oregon Dept. of Energy's Energy Efficiency & Conservation Block Grant for electric vehicle charging infrastructure.

Start Time: 7:17 p.m.

- CM Workman described resolution required to apply for a grant, noting applicability of Strategic Plan goals.
- Potential location of electrical vehicle charging stations described.
- EV station maintenance and management by a third party discussed.
- Concerns about state subsidies for for-profit organizations to operate EV charging stations expressed.
- Suggestion to write into a contract a gas tax fee for use of an EV station.

Action: To approve Resolution 24-11, authorizing the City of Philomath to apply for Oregon Department of Energy's Energy Efficiency and Conservation Block Grant and appointing the Assistant City Manager to implement the grant.

Motion/Second: Councilor Causey/Councilor Nielson

- Discussion about the cost to the City for a required match.

Vote: Action APPROVED 6-0 (Yes: Andrade, Causey, Crocker, Lehman, McMorran, and Nielson; No: None).

2. Resolution 24-12 Adopting the Storm Drainage Master Plan.

Start Time: 7:26 p.m.

- CM Fear introduced Ray Engle, Westech Engineering, to answer questions regarding the Storm Drainage Master Plan.
- Plan lack of integration with other plans that address environmental-related issues.
- NPDES permit requirements for stormwater retention addressing environmental issues described.
- Study area inclusion of Urban Growth Boundary addressed by Mr. Engle.
- Private culvert maintenance responsibility discussed.
- Councilor Andrade proposed adding a sentence regarding addition of a disclaimer statement that addresses future potential zoning changes.

- 1 • CM Workman discussed the planning evaluation process addressed during a
- 2 development project
- 3 • Edit language to make it non-gender, specifically 6-7 that addresses a hypothetical
- 4 homeowner.

5  
6 Action: To approve Resolution 24-12 adopting the Storm Drainage Master Plan  
7 dated May 2024 and replacing all previous versions and updates.  
8 Motion/Second: Councilor McMorrان/Councilor Andrade  
9 Vote: APPROVED 6-0 (Yes: Andrade, Causey, Crocker, Lehman, McMorrان  
10 and Nielson; No: None).

11 **G. REPORTS OF BOARDS, COMMISSIONS, COMMITTEES, COUNCIL LIAISONS AND**  
12 **STAFF**

13 Start Time: 8:00 p.m.

14 1. Management Report

- 15 • CM Workman introduced the monthly report included in the meeting packet.
- 16 • Laserfiche document management project described by City Recorder Post.
- 17 • Department activities and projects summarized.

18 2. Additional Reports

- 19 • Councilor Lehman noted the Philomath Boulevard Conceptual Design Open House and
- 20 the project under review.
- 21 • Question from Councilor Andrade about traffic counting strips recently seen on Main
- 22 Street.
- 23 • Councilor McMorrان reported on last week's Chamber Business After Hours event.
- 24 • Music in the Park Councilor table discussed and staff will resend the sign-up sheet.
- 25 • Councilor Nielson reported May 31 is PYAC Fundraising Carnival, School District
- 26 meetings regarding the 16<sup>th</sup> Street Project, assistance from Hughes Excavating on PCS
- 27 parking lot, and a new contact regarding a possible grocery store.

28  
29  
30 **INFORMATION & CORRESPONDENCE**

- 31 • No comments.

32  
33 **H. ADJOURNMENT**

34 Meeting adjourned at 8:14 p.m.

35 SIGNED:

ATTEST:

36  
37 \_\_\_\_\_  
38 Ruth Causey, Council President

\_\_\_\_\_  
Ruth Post, MMC, City Recorder



## Philomath City Council Agenda Item Summary

---

Title/Topic: Management Report – June 2024

---

Meeting Date: June 10, 2024  
Staff Contact: Chris Workman

---

### ISSUE STATEMENT

The following management updates are intended to keep the Council apprised of work taking place within each of the various City departments. If there are specific questions about the topics listed or any other item of interest, please contact me directly prior to the meeting and I will come prepared to answer your questions or concerns as best as possible.

### ADMINISTRATION

- Chelsea completed the 2023-24 Northwest Women's Leadership Cohort on June 7th.
- Working with Public Art Committee on a Request for Proposals for downtown plinth art.
- Park Advisory Board is working on code update recommendations related to Board operations for Council to consider at a later date.
- The filing period for the Mayor and three City Council positions at the November General Election opened on June 5th. The deadline to complete the filing process is August 13, 2024 at 5:00 p.m. A press release was issued to local media, the website has been updated with a link on the home page, and a Facebook post has been made. The Philomath News has already posted an article.
- Building permit activity has picked up with the beginning of the summer construction season. Three new single-family dwelling permits were issued in May.
- Continuing to meet with Gerding Builders, Frameworks Architects, Devco Engineering, the Frolic & Rodeo, and Bleachers International to finalize design and determine funding/phasing of the grandstands project at Skirvin Park.
- Hosted first meeting of the Scenic Byway Corridor Management Plan Steering Committee.
- Along with Councilor McMorran, met with the regional coordinator for the U.S. Department of Energy's (DOE) Energy Transitions Initiative Partnership Project (ETIPP) which works alongside remote and island communities to develop energy efficiency plans. This would provide \$50,000 to the City and roughly \$250,000 value of consulting services if the City is selected.
- Met with Sandra Peterson with Oregon Cascades West Council of Governments to discuss grant writing services. This is a new program the COG is offering its member jurisdictions. City will pay an hourly rate for grant writing and grant management.
- First Music in the Park events of the summer were held in May.
- Chris and Chelsea will attend the Oregon City County Manager's Association annual conference at the end of the June.

### Planning

- Chris is continuing to serve as city planner with support from Leilani and Ruth.
- We have received several applications for the planner position and will begin interviewing over the next two weeks.
- Continuing work on Development Code review; finalized draft of zoning map amendments.
- Approved an application for a new coffee drive through on Main Street across from True Value, with some conditions.
- Public hearings for annexation and zone change of a property on N 9th Street are scheduled for June with Planning Commission and July or August with City Council.

#### Human Resources

- Currently recruiting an Associate Planner and Police Officers.

#### POLICE

- Officer Thomas DeVicq graduated from the DPSST Police Academy on May 24<sup>th</sup>.
- Officer's completed the Bike Rodeo at Philomath Elementary School.
- Office Admin Assistant is out on maternity leave

#### PUBLIC WORKS

- Water system flushing has been completed. Everything went very well this year.
- The S 16<sup>th</sup> Street/ Sewer Improvement project is underway. The new roadway from on Cedar between 16<sup>th</sup> and 17<sup>th</sup> has been cut in and rocked for construction with the sewer line most likely installed by this meeting and the waterline from 16<sup>th</sup> to 17<sup>th</sup> underway. N 16<sup>th</sup> Street sewer portion is scheduled to start on June 3<sup>rd</sup>. June 21<sup>st</sup> is the expected start time to be doing the road work on S. 16<sup>th</sup> next to the school since they have a very short window of construction time to complete that section. Sewer line replacement and lining will continue from now through the end of the project.
- Repair plan for the reservoir has been signed off on and we hope to see repairs starting by the end of June.
- We had 8 of the worst leaking Sewer Manholes repaired and sealed by low bidder Underground Tech from Lebanon.
- The 2 wooden poles for the antennas for the remote meter reading system have been delivered and will be installed around June 12<sup>th</sup> with the rest of the system following shortly after.
- We will be preparing the area for the Starlight generator after the pole for the meter reading system is installed.
- We have a new employee on board. Russ Howard started on May 24<sup>th</sup>. Is replacing Andrew Turner who was with us about 4 or 5 months, but had to leave and move out of the area due to family issues.

#### FINANCE

- 2024-25 Fiscal Year Budget was approved by the Budget Committee and is moving forward to the City Council.
- Started work on a payroll overtime recalculation issue that will impact some employees.

**Official Newsletter of the City of Philomath**

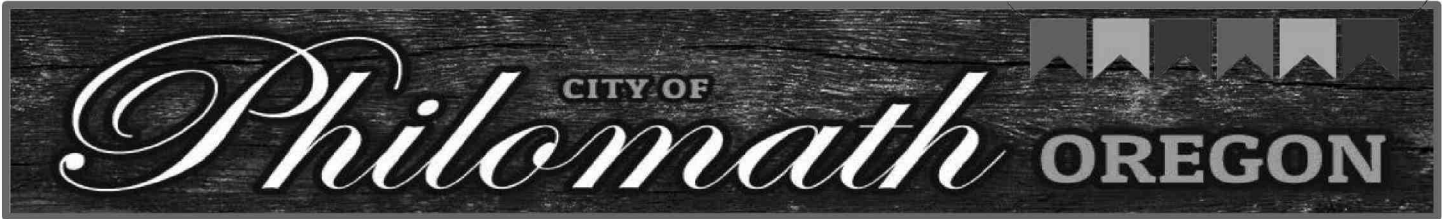

**Mayor & City Council Election Filing  
Period Opens June 5<sup>th</sup>**

At the 2024 General Election, the positions of Mayor and three City Councilor positions will appear on the ballot. In addition to Mayor Chas Jones, Councilors Ruth Causey, Diane Crocker and Christopher McMorran have terms expiring this year. The filing period for interested candidates begins on June 5, 2024.

**Deadline to complete filing process:** August 13, 2024, at 5:00 p.m.

- All positions are nonpartisan.
- All positions are volunteer/non-paid.
- All terms begin on January 1, 2025.
- The term for the position of Mayor is four years.
- The term for the positions of City Councilor are four years.
- Council positions are elected at large, meaning candidates may reside in any area within the city limits.

**Qualifications and Residency Requirements:**

- To be eligible for an elective city office, a person at the time of election must be a qualified elector within the meaning of the state constitution and have resided in the city during the twelve months immediately preceding the election. For purposes of this subsection, "city" means all areas included in the corporate limits as of the date of the election.
- No person may be a candidate for the offices of mayor and council at the same election.

Interested citizens should make an appointment with City Elections Official, Ruth Post, to determine if they meet the qualifications and residency requirements and to learn more about the expectations of serving on the City Council. Additional information is also available on the City's website at [www.ci.philomath.or.us/elections](http://www.ci.philomath.or.us/elections).



PHILOMATH  
MUSEUM  
UPCOMING  
EVENTS

**Philomath Museum Master Plan- Community Conversations**

The Philomath Museum is making plans for how to better serve the community. Please join us for one of three scheduled community conversations to share your input! No need to RSVP, just come by.

June 15<sup>th</sup> 2pm · June 19<sup>th</sup> 10:30am · June 24<sup>th</sup> 3pm

If you have questions or want to send feedback via email, please reach out to Executive Director Jessica Hougen at:

[jessica@bentoncountymuseums.org](mailto:jessica@bentoncountymuseums.org)

**Philomath  
Farmers' Market  
Sundays 11 to 3**

Fresh Veggies		Wood-Fired Pizza
Live Music		Fresh Fruit
Baked Goods		Handmade Goods
Community Outreach		Family Fun!!

**Philomath Community Library  
May 26th to October 20th**

# Good Fences Make Good Neighbors – Building a Fence in Philomath

As summer approaches, homeowners often embark on various projects to enhance their property. Among these, installing a new fence can significantly improve aesthetics and privacy. Before diving in, it's crucial to ensure your new fence is built in adherence to local codes.

One important thing to keep in mind are height restrictions. Front yard fences can be no higher than 4 feet and back yard fences are limited to 6 feet. Front fences must be "open sighted" which refers to fences or materials providing for 50 percent or less vision obstruction. Corner lots, and fences on retaining walls, have special provisions to allow for visual clearance.

City staff are regularly consulted about setbacks for new fences. Setbacks are related to how close the fence can be built to a building, street, or property line. It's important to confirm setbacks before building your fence so make sure to look for property pins or consult with a surveyor prior to breaking ground. Even if your current neighbor is okay with your proposed fence placement, the next one may not be and removing a new fence is not on anyone's summer fun list!

Visit the City's Fence, Hedge & Wall Standards page for residential fence diagrams and Code language: [bit.ly/4dN7lrj](http://bit.ly/4dN7lrj), or call the Planning Department at 541-929-6148, Option 4. As the saying goes, "good fences make good neighbors", so reach out and we will help you get things right the first time!



Check out the Chamber Calendar for more events in the Philomath Area:  
[www.philomathchamber.org/](http://www.philomathchamber.org/)



City Offices Closed  
June 19th in observance of  
**Juneteenth**  
Bus Service on Regular  
Schedule



**JUNE MEETINGS**

- June 4** Park Advisory Board 5:30 PM
- June 5** Public Art Committee 5:30 PM
- June 10** City Council regular meeting 7:00 PM
- June 17** Planning Commission 6:00 PM
- June 19** Juneteenth Holiday – Offices Closed  
Philomath Connection bus service on regular routes
- June 24** City Council
- June 25** Inclusivity Committee 5:30 PM
- TBD** Housing & Economic Development

Additional City committee and board meetings may be added to the calendar later in the month.

**For the most up to date schedule, agendas and participation details, go to:**  
[City Meetings & Events Calendar](#)

Watch meetings via live-stream on



**Thursday, June 20 – 6-8 PM · Revel'n**  
Bluegrass & Old Time Country

**Sunday, June 30 – 6-8 PM · DRTR**  
Americana & Blues

Music in the Park is a FREE concert series held at City Park, 299 S 23<sup>rd</sup> Street. Concerts take place the 3<sup>rd</sup> Thursday and last Sunday of each month, May-August from 6 pm-8 pm. This concert series is fun for the whole family! Bring a chair and relax on the lawn while enjoying a variety of music. Come back twice a month all summer to experience all the bands! Concessions available: Lion's Club burgers and hotdogs on Thursdays & Mud Oven Pizza on Sundays!

**Thank you Pioneer Connect, who is returning as the series sponsor for 2024!**



Thank you sponsors:  
Strengthening Rural Families  
and Dirt Road Brewing.



SUBSCRIBE TO RECEIVE CITY EMAILS:

**SUBSCRIBE**

KNOW WHAT'S GOING ON IN YOUR COMMUNITY!

Default Data  
Click to select your data

May 1, 2024 - May 31, 2024

Video Title: City & Urban Renewal A... (11)

Trending

Views  
**706.0**

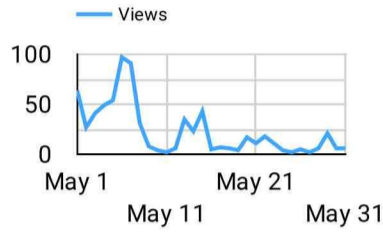

Total Watch Time  
**298:53:07**

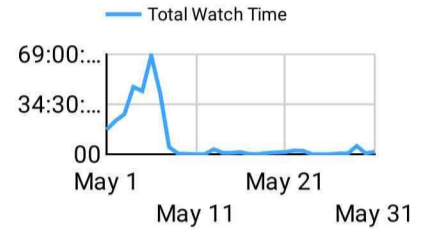

Video Shares  
**4.0**

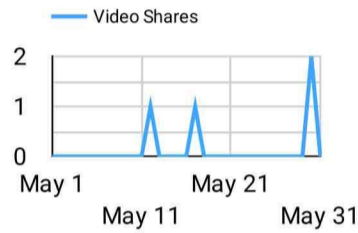

Avg. View Duration  
**25:24**

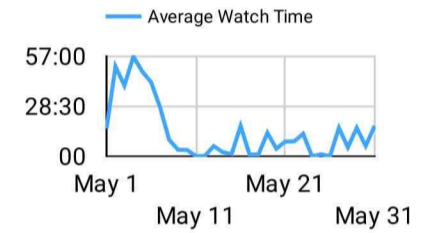

Top Videos Watched

Video Title	Views	Average Watch Time
Planning Commission meeting 4/15/2024	196	00:57:33
City Council & Urban Renewal Agency meeting 2/12/2024	78	00:25:47
City & Urban Renewal Agency Budget Committee 5/1/2024	54	00:06:52
City Council meeting 2/27/2023	47	00:00:16
Police Committee 5/14/2024	29	00:05:47
Planning Commission 5/20/2024	25	00:15:25
City Council Meeting 5/13/2024	23	00:08:37
Planning Commission 4/1/2024	22	01:00:14
Park Advisory Board 5/7/2024	21	00:09:16
Public Works Committee 4/4/2024	19	00:16:30

1 - 10 / 61

Likes, Comments, and Subscriptions

Likes

**25:24**



Subscriptions

**62**

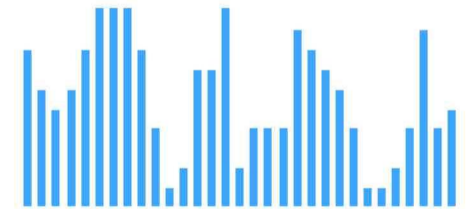

Dislikes

**22%**

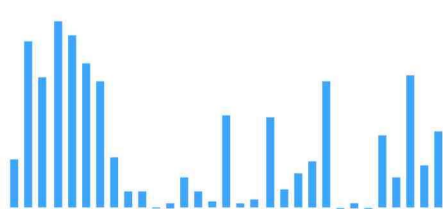

Comments

**0**



## Philomath Connection Bus Ridership Monthly Totals

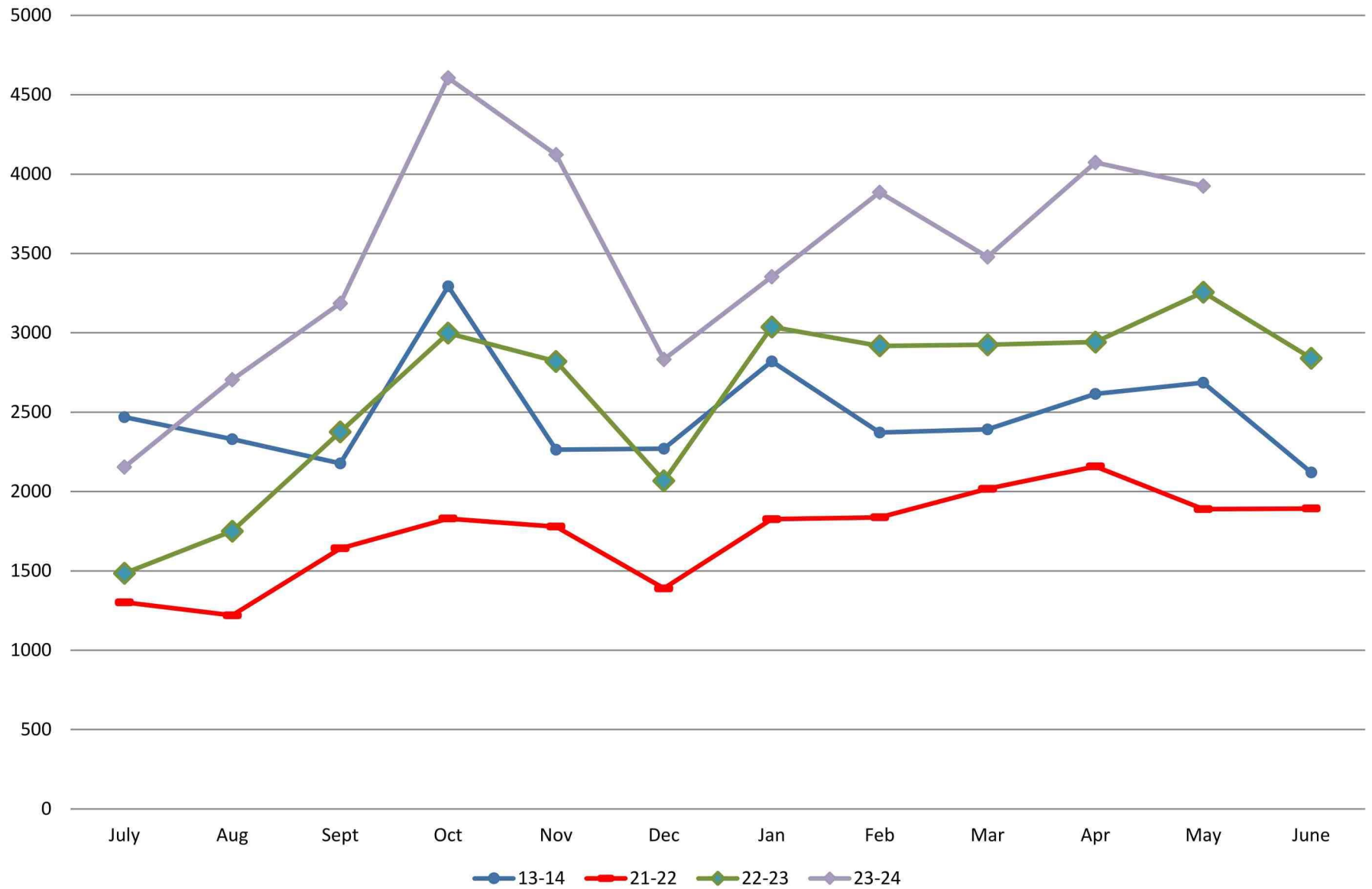



Daily Philomath Connection Riders: May 2024

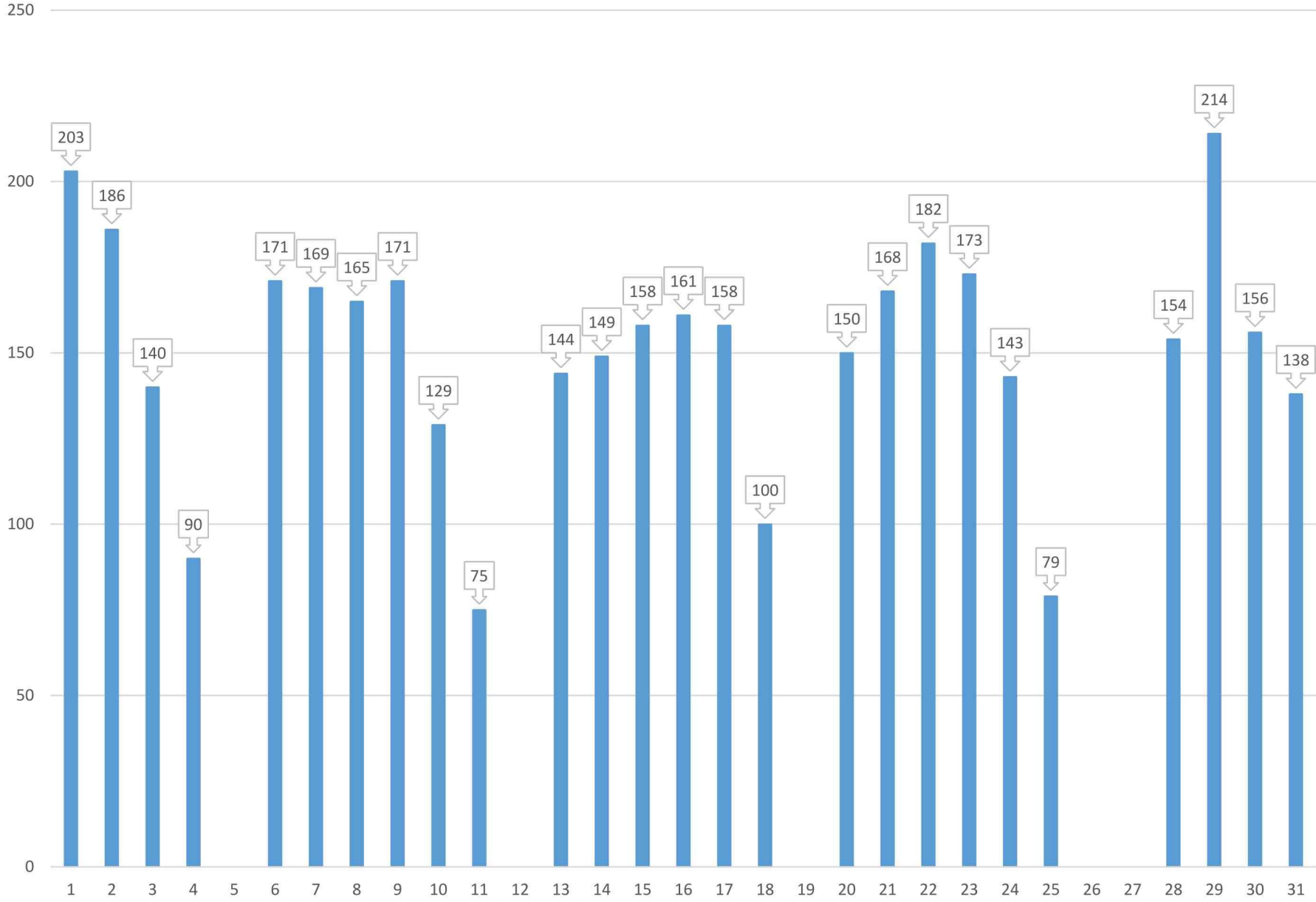

**PHILOMATH CONNECTION RIDERSHIP SUMMARY**

<b>2023-2024 SUMMARY</b>	<b>TOTAL RIDES -</b>	<b>38,322</b>	<b>DAYS OF SERVICE-</b>	<b>281</b>	<b>AVG RIDE/DAY-</b>	<b>136</b>
<b>2022-2023 SUMMARY</b>	<b>TOTAL RIDES -</b>	<b>31,414</b>	<b>DAYS OF SERVICE-</b>	<b>275</b>	<b>AVG RIDE/DAY-</b>	<b>114</b>
<b>2021-2022 SUMMARY</b>	<b>TOTAL RIDES -</b>	<b>20,783</b>	<b>DAYS OF SERVICE-</b>	<b>307</b>	<b>AVG RIDE/DAY-</b>	<b>68</b>
<b>2020-2021 SUMMARY</b>	<b>TOTAL RIDES -</b>	<b>12,025</b>	<b>DAYS OF SERVICE-</b>	<b>333</b>	<b>AVG RIDE/DAY-</b>	<b>36</b>
<b>2019-2020 SUMMARY</b>	<b>TOTAL RIDES -</b>	<b>16,277</b>	<b>DAYS OF SERVICE-</b>	<b>308</b>	<b>AVG RIDE/DAY-</b>	<b>53</b>
<b>2018-2019 SUMMARY</b>	<b>TOTAL RIDES -</b>	<b>16,306</b>	<b>DAYS OF SERVICE-</b>	<b>306</b>	<b>AVG RIDE/DAY-</b>	<b>53</b>

<b>MONTH</b>	<b>DAYS OF SVC</b>	<b>TOTAL FOR MONTH</b>	<b>AVERAGE RIDES PER DAY</b>
--------------	--------------------	------------------------	------------------------------

<b>2023-2024</b>			
JULY	25	2,154	86
AUGUST	27	2,704	100
SEPTEMBER	25	3,185	127
OCTOBER	26	4,606	177
NOVEMBER	26	4,123	159
DECEMBER	25	2,832	113
JANUARY	24	3,354	140
FEBRUARY	25	3,885	155
MARCH	26	3,479	134
APRIL	26	4,074	157
MAY	26	3,926	151
JUNE	25		

<b>2022-2023</b>			
JULY	25	1,485	59
AUGUST	27	1,750	65
SEPTEMBER	23	2,376	103
OCTOBER	21	2,998	143
NOVEMBER	21	2,820	134
DECEMBER	21	2,067	98
JANUARY	22	3,037	138
FEBRUARY	20	2,918	146
MARCH	23	2,925	127
APRIL	20	2,942	147
MAY	26	3,256	125
JUNE	26	2,840	109

**RIDERSHIP BY WEEK FOR THE MONTH**

<b>PC ROUTE</b>	<b>May 1-4</b>	<b>May 6-11</b>	<b>May 13-18</b>	<b>May 20-25</b>	<b>May 28-31</b>
<b>MONTHLY TOTAL</b>	619	880	870	895	662



# CITY OF PHILOMATH

## Activity Report/ Ongoing Projects

May 20, 2024

1. Received an application for a drive-thru coffee shop at 1731 Main Street. Public Comment period ends 17 May 2024.
2. Issued decision on application for an ADU at 603 Coastal View Dr.
3. Issued decision on application for a reader board sign for Philomath Fire and Rescue at 1035 Main St.
4. Received applications for annexation and Zoning Map/Comprehensive Plan Amendment at 769 N 9<sup>th</sup> St. Planning Commission public hearing scheduled for 17 June 2024, which will be followed by a public hearing before the City Council in July.
5. Building permits issued for April 2024 were as follows:

Single Family Residential.....	0
Residential Structural (other) .....	2
Residential Electrical.....	7
Residential Mechanical .....	12
Residential Plumbing .....	5
Residential Manufactured Dwelling .....	0
Residential Demo.....	0
Commercial Structural .....	0
Commercial Electrical .....	3
Commercial Mechanical.....	0
Commercial Plumbing.....	2
Commercial Alarm/Suppression.....	2
Commercial Demo .....	0

Commercial permits are for Philomath Church of Nazarene, Philomath Self Storage LLC, and a couple minor regular maintenance projects.

**PHILOMATH PLANNING COMMISSION  
REGULAR MEETING MINUTES  
Philomath City Hall Council Chambers  
May 20, 2024**

**1. CALL TO ORDER - ROLL CALL**

Meeting called to order at 6:00 p.m. by Chair Gary Conner.

**Present:**

Gary Conner  
John Barlow  
Van Hunsaker  
Timothy Melott  
Darlene Rose  
Ruth Causey, City Council liaison

**Absent:**

Hayley Green  
Josiah Jessen

**Staff Present:**

Chris Workman, City Manager

**2. APPROVAL OF MINUTES**

**2.1 May 20, 2024**

Action Approve minutes as presented.  
Motion/Second: Commissioner Hunsaker/Commissioner Rose  
Vote: APPROVED 5-0 (Yes: Conner, Barlow, Hunsaker, Melott and Rose; No: None).

**3. UNFINISHED BUSINESS**

**3.1 Development Code Residential Section Review**

Start Time: 6:02 p.m.

- City Manager Workman provided some model code from DLCD that he is using as a reference for updating our code. Seeking input from Commission for areas to look at that our current code doesn't address.
- Follow-up discussion from last meeting on housing density, lot coverage and minimum standards.
- Impact on densities when narrowing street widths discussed and the use of minimum and maximum lot sizes to affect density.
- Development on oversized lots discussed.
- Lot coverage and lot coverage bonus concept reviewed. Affordable housing as a potential bonus to be further researched by staff.
- Request for review of the lot coverage table to compare to other cities and examples of different lot coverage percentage points.
- Impact of not maximizing coverage and resulting urban growth boundary expansions described.
- Special Use Standards model code language introduced.
- Duplex standards discussed.
- Widths of townhomes discussed and other model townhome special standards discussed.
- Discussion about standard for percentage of private open space. Staff to review current standard percentage.
- Staff to draft language regarding State mandates that trump City standards.
- Discussion about non-conforming replacement language for houses that are demolished rather than destroyed.
- Discussion about setback requirements for reconstruction of a destroyed dwelling unit in the commercial zone.

- 1 • Discussion about continuation of non-conforming structures with current code
- 2 language or possible amendments to address replacement options.
- 3 • Staff to return with draft language for review regarding elimination of reconstruction
- 4 of non-conforming structures.
- 5 • Staff to review day care facility language in model and compare to current code.
- 6 • Signage and exterior appearances of care facilities discussed.
- 7 • Discussion about home occupations, permit applications, and associated restrictions.
- 8 • Potential for expansion of commercial activities within home occupations discussed.
- 9 • Staff to develop language for commercial in a residential application process.
- 10 • Manufactured home parks briefly discussed.
- 11 • Temporary use permits outside of seasonal and special events reviewed and
- 12 differences between what would be allowed for residential zones versus commercial
- 13 discussed.
- 14 • Temporary buildings such as sales offices and construction trailers discussed.
- 15 • Accessory dwelling units discussed, including maximum square footages,
- 16 percentage compared to existing dwelling, and state statutes.
- 17 • Minimum lot sizes and maximum lot coverage for ADUs discussed, particularly
- 18 referencing townhomes and duplexes.
- 19 • Definition of independent living space discussed.
- 20 • Staff to review state mandates related to lot size or lot coverage for ADUs.
- 21 • Difference between bed and breakfast inns and Airbnb rentals discussed briefly.
- 22 • Cottage housing previously discussed.
- 23 • Micro-generation facilities discussed related to standards and types of facilities.
- 24 • Brief discussion about parks and open spaces requirements in current code related
- 25 to new development requirements and current method for collecting park SDCs.
- 26 • Vacation rental dwellings discussed, including current process of treating it like a
- 27 home occupation, review process and transient lodging tax.
- 28 • Wireless Communication Facilities discussed, including new Public Works antennas
- 29 for gathering water meter data.
- 30 • 2:20:36

31 **4. ANNOUNCEMENTS & STAFF UPDATES**

32 Start Time: 8:29 p.m.

33 **4.1 Staff Update**

- 34 • Commission briefed on upcoming public hearing for annexation and zoning.
- 35 • Update on Cochran Memorial Park amenities and usage.

36 **4.2 Regular Meeting: June 17, 2024, at 6:00 PM**

37 **5. ADJOURNMENT**

38 Meeting adjourned at 8:35 p.m.

39 SIGNED:

40

41

42 \_\_\_\_\_  
43 Gary Conner, Chair

44

ATTEST:

\_\_\_\_\_  
Ruth Post, MMC, City Recorder

**PHILOMATH PARK ADVISORY BOARD  
MEETING MINUTES  
Philomath City Hall Council Chambers  
May 7, 2024**

**1. ROLL CALL**

Meeting called to order at 5:32 p.m. by Chair Larry Sleeman

**Present:**

- Larry Sleeman, Chair
- Yvonne McMillan, Vice Chair
- Rose Bricker
- Owen Cass
- Lindy Young
- Tyler Pellett

**Absent:**

- Scott Austin

**Staff Present:**

Chelsea Starner, Assistant City Manager

**2. APPROVAL OF MINUTES**

1. Minutes from the April 2, 2024, Park Advisory Board meeting

Start Time: 5:32 p.m.

Action: To approve the minutes

Motion/Second: Pellett/Cass

Vote: Action APPROVED 6-0 (Yes: Bricker, Cass, McMillan, Pellett, Sleeman, Young; No: None)

Added time for public to speak:

- Bill Caffey spoke in favor of adding a dog park in Philomath.
- Jane Sherwood (Inclusivity Committee member) approached the Board for support hosting a table at Music in the Park events to gather information from the public on how to be a more age friendly and overall inclusive community.

**3. BUSINESS**

1. Music in the Park Planning

Start Time: 5:48 p.m.

- Reviewed volunteer duties during concerts
- Discussed sandwich board storage location and retrieval for concerts.
- Members coordinated for coverage at May events.
- Philomath Performing Arts Benefit Fund participation was discussed.

2. Flossie Overman Park

Start Time: 6:02 p.m.

- Condition of the park was discussed after several communications from the public over the maintenance of it.
- Discussed staff time issues; the City does not have any dedicated park worker positions.
- Volunteers time spent at parks has diminished but may be an idea for work parties in the future.
- Talked about organizing a “friends of Philomath parks” program; Ms. Starner noted it is not in the Strategic Plan but she will speak with other staff about volunteer coordination in Philomath.
- 

**4. STAFF AND BOARD UPDATES**

1. Park project updates

- a. Paul J. Cochran Memorial Park construction

1  
2  
3  
4  
5  
6  
7  
8  
9  
10  
11  
12  
13  
14  
15  
16  
17  
18  
19  
20  
21  
22  
23  
24  
25  
26  
27  
28  
29  
30  
31  
32

Start Time: 6:16 p.m.

- Staff noted the sign is up and residents are using the park. The pavilion and memorial are outstanding to be constructed.
- Discussed Rotary gathering on Memorial Day.
- Question about adding shade to park; there are no other shade structures planted but trees have been planted.
- Young to reach out to Public Works about flags.

b. Skatepark

Start Time: 6:21 p.m.

- Bricker talked about Build a Better Skatepark (BABS) which is hosting upcoming online meeting.
- BABS attended recent City of Corvallis Skatepark opening.

2. Board Member Updates

Start Time: 6:26 p.m.

- Young: Asked about the reservoir project progress.
- McMillan: Talk Like a Pirate Day Fundraiser Dance on May 24 at the Frolic Grounds.
- Sleeman: Noted the new name sign at City Park and encouraged others to go see it. Brought up directional signage to City Park on Applegate.
- Cass: Benton Soil and Water Conservation District Let's Pull Together events on May 18.

3. Future Discussion Items

Start Time: 6:35 p.m.

- Volunteers at parks; dog park (waiting for Master Plan update); Music in the Park; Build a Better Skate Park; Park Board Municipal Code update.

**5. ADJOURNMENT**

Meeting adjourned at 6:37 p.m. by Chair Sleeman. Next meeting is June 4, 2024.

Respectfully submitted by: Chelsea Starner, Assistant City Manager

PHILOMATH POLICE COMMITTEE  
MINUTES  
May 14, 2024

Philomath City Hall  
980 Applegate Street

ROLL CALL:

Present: Chair Teresa Nielson, City Councilor Diane Crocker and City Councilor Ruth Causey.  
Staff Present: City Manager Chris Workman and Police Chief David Gurski.

MINUTES APPROVAL:

Action: Approve minutes from February 13, 2024 and June 13, 2023 as presented.  
Motion/Second: Causey/Crocker

UPDATE – PERSONNEL BRIEFING:

- Officer Scott Andrade did not pass probationary training.
- Currently recruiting for a lateral officer.
- Officer Thomas Dviqc graduates DPSST May 24 and will start his training in Philomath.
- Training process was explained.
- Regional hiring was discussed.
- Appreciation expressed to Sargent Bowers for taking on the DRE (drug recognition) training/role.

WILDLIFE:

- Bear and cougar sightings and turkeys discussed.
- ODFW is interested in hearing from neighbors who want turkeys trapped. Contact Greg Reed [gregory.c.reed@odfw.oregon.gov](mailto:gregory.c.reed@odfw.oregon.gov). Information to be posted in the newsletter and on social media.

TRAFFIC N 15<sup>TH</sup> STREET AREA:

- Officers have been there multiple days during lunch period and not observed violations.
- Discussion of citizen-requested crossings across 13 and 15 Streets.
- Discussion of speeds in school zones.

GOLF CARTS ON PUBLIC ROADS:

- For golf carts to be permitted to drive on a state road, Oregon statute requires there to be a golf course. Philomath does not have a golf course.

OTHER ITEMS:

- Discussion of contracting out for police services. Topic will be covered in more depth at the next Budget Committee meeting.
- Discussion of code compliance officer position and who will be picking up these tasks with the promotion of our code compliance officer to a full-time officer.
- Discussion of high grass and need for complaint to the non-emergency police number to get officers into the neighborhood to give warnings and citations.

- Discussion about how far from a corner you can park and example of neighbors discussing this with others in violation.
- Request for a quarterly report showing when officers are engaged with residents/businesses/youth in events around town to help shine positive light on the Department. "Chief's Corner" in City Newsletter. Farmer's Market appearance.

Meeting adjourned at 4:47 p.m.

Next meeting: July 9, 2024 at 4:00 p.m.

Minutes recorded by Chris Workman, City Manager.

DRAFT

**PHILOMATH BUDGET COMMITTEE  
MINUTES  
Philomath City Hall Council Chambers  
May 15, 2024**

**1. CALL TO ORDER - ROLL CALL**

Meeting called to order at 5:37 p.m. by Chair Brent Kaseman.

**Present:**

Teresa Nielson, Ruth Causey, Diane Crocker, Mark Koepp, Van Hunsaker, Brent Kaseman, Jessica Andrade, Matt Lehman, and Christopher McMorran.

**Staff Present:**

Chris Workman, City Manager; Chelsea Starnier, Assistant City Manager; Mike Murzynsky, Finance Director; David Gurski, Chief of Police; Kevin Fear, Public Works Director; Garry Blac, Operations Supervisor.

**Absent:**

David Low, Chas Jones, Deanna Montiel and Jeff Schiminsky.

**2. APPROVAL OF MINUTES**

Start Time: 5:38 p.m.

Action: Approve minutes of May 1, 2024.

Motion/Second: Causey/Nielson

Vote: APPROVED 9-0 (Yes: Teresa Nielson, Ruth Causey, Diane Crocker, Mark Koepp, Van Hunsaker, Brent Kaseman, Jessica Andrade, Matt Lehman, and Christopher McMorran. No: None).

**3. REVIEW/RESPOND TO QUESTIONS FROM FIRST MEETING**

Start Time: 5:39 p.m.

Discussion:

- Finance Director Murzynsky reviewed presented questions and answers listed on the Finance memorandum.
- Question 4: Discussion on which figures reflect how much revenue is decreasing.
- Question 7: Discussion on what is spent in miscellaneous and whether we can separate some of the items.

Action: To correct Building and Grounds personnel budget, custodian amount of \$28,802 needs to be moved to ending fund balance of general fund.

Motion/Second: Causey/Hunsaker

Vote: APPROVED 9-0 (Yes: Teresa Nielson, Ruth Causey, Diane Crocker, Mark Koepp, Van Hunsaker, Brent Kaseman, Jessica Andrade, Matt Lehman, and Christopher McMorran. No: None).

- Question 18: Council's Education & Training line-item requested to be increased.

Action: Motion to increase line item 10-9-5245 from \$6,000 to \$10,000 making a \$4,000 transfer from ending fund balance.

Motion/Second: Andrade/McMorran

- 1           • Training in City Council budget was discussed.  
2       Vote:           APPROVED 5-4 (Yes: Mark Koeppe, Van Hunsaker, Jessica Andrade,  
3                           Matt Lehman, and Christopher McMorran. No: Causey, Crocker, Nielson,  
4                           and Kaseman).

- 5  
6           • Questions 19 and 20: correction of accounts due to month-end process being  
7                           overlooked.

8  
9       Action:           Increase beginning fund balance general fund \$21,128.17, street fund  
10                           \$8,299, water fund \$3,447, sewer fund \$1,483 and decrease ending fund  
11                           balance by same.

12       Motion/Second: Crocker/Causey

13       Discussion:

- 14           • Discussion on whether numbers are in line with last year. FD Murzynsky confirmed it  
15                           was in line with budget and just making correction.

16       Vote:           APPROVED 9-0 (Yes: Teresa Nielson, Ruth Causey, Diane Crocker,  
17                           Mark Koeppe, Van Hunsaker, Brent Kaseman, Jessica Andrade, Matt  
18                           Lehman, and Christopher McMorran. No: None).

- 19  
20           • Questions 23 and 24: discussion on review of Land, Building, and Equipment fund,  
21                           SDC—Governmental, and SDC—Proprietary, Street, Water, and Storm Water funds.

22  
23       Action:           Motion to accept changes as presented to the budget committee in  
24                           document sent 5/14/2024 by email.

25       Motion/Second: Crocker/Causey

26       Vote:           APPROVED 9-0 (Yes: Teresa Nielson, Ruth Causey, Diane Crocker,  
27                           Mark Koeppe, Van Hunsaker, Brent Kaseman, Jessica Andrade, Matt  
28                           Lehman, and Christopher McMorran. No: None).

- 29  
30           • Assistant City Manager Starner presented responses from memorandum dated May  
31                           6, 2024.  
32           • Police Chief Gurski presented responses from memorandum dated May 8, 2024.  
33                           • Question 8: Noted the City's pay scale is lower than the County. In addition,  
34                           vehicle and maintenance, etc. would also need to be paid for.  
35                           • Question 12: Recommend considering splitting this into more categories.  
36                           • Question 25: Discussion on why purchasing new weapons and caliber  
37                           changes.  
38                           • Public Works Director Fear presented responses from memorandum dated  
39                           5/8/2024.  
40                           • Question 22: Councilor Hunsaker spoke in favor of presented budget  
41                           numbers in order to purchase things when needed.  
42                           • Question 32: Discussion about fall surfaces used in Westbrook Park vs  
43                           Cochran Park.

44  
45       **4. BUDGET COMMITTEE DISCUSSIONS & DELIBERATIONS**

46       Start Time:   6:38 p.m.

47       Discussion:

- 1 • Revisit discussion from previous meeting on tree canopies and community events,
- 2 adequate funding, and where funding comes from if needed.
- 3 • Discussion about programs and where to allocate funds.

4  
5 Action: Move to add a \$2,000 line item to Parks budget for tree canopy project,

6 with the understanding the city will look for external funding.  
7 Motion/Second: McMorran/Neilson

- 8 • Discussion about line item, complication with other tree purchases. Staff confirmed a
- 9 new line item would be made.

10 Vote: APPROVED 9-0 (Yes: Teresa Nielson, Ruth Causey, Diane Crocker,  
11 Mark Koepp, Van Hunsaker, Brent Kaseman, Jessica Andrade, Matt  
12 Lehman, and Christopher McMorran. No: None).

- 13
- 14 • Discussion about total proposed 24/25 budget and reserve recommendations of
- 15 42%; how to manage a potential shortfall.

16  
17 **5. VISITORS COMMENTS**

18 6:56 p.m.

- 19 • None.

20  
21 Discussion:

- 22 • City Manager discusses next steps in Budget process.
- 23 • Discussion about date of June meeting to adopt Budget, which was confirmed as
- 24 June 10.

25  
26 **6. ADJOURNMENT**

27 Next meeting May 22, 2024, at 6:00 p.m. Meeting adjourned at 7:01 p.m.

28  
29 SIGNED:  
30 Brent Kaseman, 2024-2025 Chair

ATTEST:  
Ruth Post, MMC, City Recorder

**PHILOMATH BUDGET COMMITTEE  
MINUTES  
Philomath City Hall Council Chambers  
May 22, 2024**

**1. CALL TO ORDER - ROLL CALL**

Meeting called to order at 6:08 p.m. p.m. by Chair Brent Kaseman.

**Present:**

Jessica Andrade, Ruth Causey, Van Hunsaker, Brent Kaseman, Matt Lehman, David Low, Christopher McMorran, Deanna Montiel, Teresa Nielson and Jeff Schiminsky

**Staff Present:**

Chris Workman, City Manager; Chelsea Starner, Assistant City Manager; and Mike Murzynsky, Finance Director.

**Absent:**

Diane Crocker, Chas Jones, and Mark Koeppe.

**2. APPROVAL OF MINUTES**

Start Time: 6:08: p.m.

Action: Approve minutes of May 15, 2024.

Motion/Second: Lehman/Causey

Vote: APPROVED 10-0 (Yes: Jessica Andrade, Ruth Causey, Van Hunsaker, Brent Kaseman, Matt Lehman, David Low, Christopher McMorran, Deanna Montiel Teresa Nielson and Jeff Schiminsky; No: None).

**3. VISITORS COMMENTS**

None.

**4. BUDGET COMMITTEE APPROVAL OF THE BUDGET DOCUMENT**

Action #1

Start Time: 6:09 p.m.

Discussion:

- Finance Director Mike Murzynsky discussed approval of the 2024-25 Fiscal Year Budget, the 2024-25 Fiscal Year Tax Rate, and moving Parks Capital outlay monies.

Action #1: Accept the removal of the \$250,000 Park project and move the monies to Contingency.

Motion/Second: McMorran/Second

- Discussion

Vote: APPROVED 10-0 (Yes: Jessica Andrade, Ruth Causey, Van Hunsaker, Brent Kaseman, Matt Lehman, David Low, Christopher McMorran, Deanna Montiel Teresa Nielson and Jeff Schiminsky; No: None).

Action #2 Discussion: Lehman: Does \$250,000 remain in park SDC

- Causey: Question about capital project shortage and ending fund balance. Asked for presentation to Council at June meeting.

- 1 • McMorran asked about the shortage on a street improvement project. Murzynsky
- 2 said he caught it and moved the money.
- 3

4 Finance

5 Action #2: Budget Committee approval of a budget for the Fiscal Year beginning  
6 July 1, 2024, and ending June 30, 2025, for the City of Philomath with  
7 Total Requirements of \$40,841,518; in accordance with the foregoing  
8 summary of Funds and changes, and further recommend that the  
9 approved budget for Fiscal Year 2024-25 be adopted by the City of  
10 Philomath City Council.

11 Motion/Second: Causey/McMorran

- 12 • Discussion
- 13 Vote: APPROVED 10-0 (Yes: Jessica Andrade, Ruth Causey, Van Hunsaker,
- 14 Brent Kaseman, Matt Lehman, David Low, Christopher McMorran,
- 15 Deanna Montiel Teresa Nielson and Jeff Schiminsky; No: None).
- 16

17 **5. APPROVAL OF AD VALOREM PROPERTY TAX RATE**

18 Action #1 Start Time: 6:16 p.m.

19 Discussion:

- 20 •
- 21 Action #1: Budget Committee approval of taxes provided for in the City of
- 22 Philomath’s Budget for the Fiscal Year beginning July 1, 2024, and
- 23 ending June 30, 2025, at the rate of \$5.3005 per \$1,000 of assessed
- 24 value.

25 Motion/Second: Causey/Hunsaker

- 26 • Discussion
- 27 Vote: APPROVED 10-0 (Yes: Jessica Andrade, Ruth Causey, Van Hunsaker,
- 28 Brent Kaseman, Matt Lehman, David Low, Christopher McMorran,
- 29 Deanna Montiel Teresa Nielson and Jeff Schiminsky; No: None).
- 30

31 **6. ADJOURNMENT**

32 Meeting adjourned at 6:17 p.m.

33  
34  
35  
36 \_\_\_\_\_  
Brent Kaseman, 2024-2025 Chair

\_\_\_\_\_   
Ruth Post, MMC, City Recorder

## 2024 Farmer's Market and Music in the Park Sign Up Sheet

In order to give everyone an opportunity to be at the market, please only sign up for a slot once every three weeks. Two councilors per week.  
Copy one of the "Potential Topics" from the list below to focus on during your week, or submit your own. Work with staff ahead of time to prepare materials.  
Remember, no campaigning or campaign material distribution at the city booth. General "get out the vote" is okay, but be careful.

FARMERS MARKET				Potential Topics
Councilor 1	Councilor 2	Topic		
26-May			Downtown Safety and Streetscapes Project	
2-Jun	Christopher McMorran	Library feasibility study & bus stop improvements?	Water Treatment Plant update	
9-Jun			Budget Process and public input	
16-Jun			City Website Improvements	
23-Jun			City Logo	
30-Jun	Christopher McMorran	Jessica Andrade	Scenic Byway	City Hall Remodel Project
7-Jul				Downtown Revitalization Plan
14-Jul				Business Retention and Development
21-Jul				REAL and other resources for Entreprunuers
28-Jul	Christopher McMorran		City Hall Remodel/City Website/City Lgo	Skirvin Park Improvements
4-Aug				16th Street Extention Project
11-Aug				Downtown Parking Plan
18-Aug	Inclusivity Committee	Inclusivity Committee	Inclusivity Committee	City Gas Tax
25-Aug	Diane Crocker		TBD	EV Charging Station Project
1-Sep	Planning Commission	Planning Commission	Zoning/Code	Downtown Directional Signage for Pedestrians
8-Sep				Scenic Byways Management Plan
15-Sep	Christopher McMorran		Voter Registration	Bus Stop Improvements
22-Sep				Skate Park Feasibility Study Results and Advocacy
29-Sep				Library Feasibility Study
6-Oct				Traffic Safety and Street Improvements
13-Oct	Planning Commission	Planning Commission	Zoning/Code	Voter Registration
20-Oct				Emergency Preparedness (Sept is Nat. Preparedness Month)
				Emergency Management Plan (Sept is Nat. Preparedness Month)
				Others:
MUSIC IN THE PARK				
Councilor 1	Councilor 2	Topic		
16-May	Christopher McMorran	Jessica Andrade	Streetscapes/skatepark/budget process?/Inclusivity Committee?	
26-May				
20-Jun	Diane Crocker		TBD	
30-Jun				
18-Jul	Teresa Nielson		16th Street Extention Project	
28-Jul	Christopher McMorran			
15-Aug	Teresa Nielson		Skirvin Park Improvements	
25-Aug	Christopher McMorran			

RAINcatalysts

# Engagement Report: 2024 Quarter 1

Linn-Benton Venture Catalyst

Nate Conroy

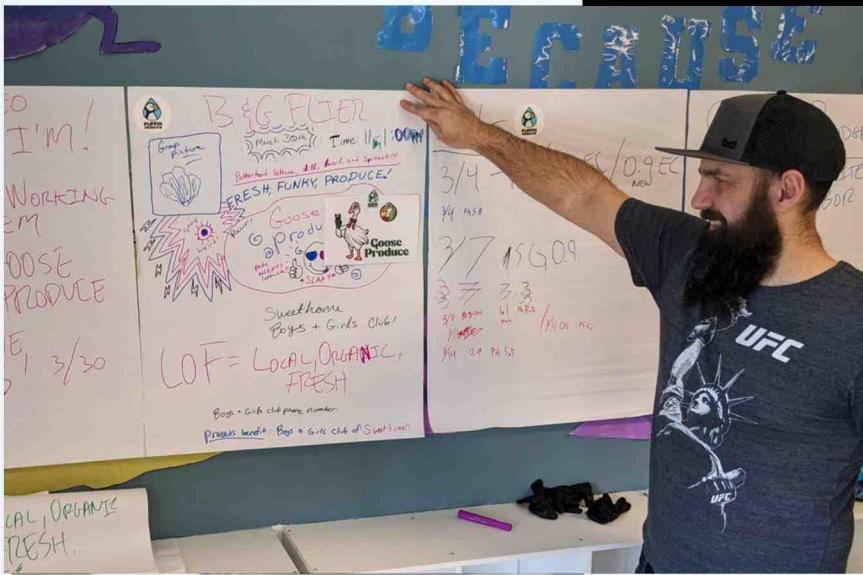

# Summary

QI was highlighted by creative ways to help find win-win opportunities to help entrepreneurs move their businesses forward while also strengthening entrepreneurial assets in the community. It's been exciting to facilitate listening sessions with entrepreneurs to identify immediate and impactful needs, then connect them with ecosystem partners and events that allow them to address those needs. I am proud of the meaningful, positive and productive relationships these efforts are producing.

**Local Entrepreneurs  
Supported: 21**

**Entrepreneur Events Hosted  
and Supported: 32**

# Highlight: Expanding Awareness of Support

Nate,  
Thank you for being at the Eggstravaganza and sharing what you do with Rain.  
I appreciate the spirit of joy and care that you have brought to each of the events we have partnered on.  
  
God bless!  
Toby



Because of intentional relationship building, RAIN is increasingly asked to set up at events like the Eggstravaganza in Adair Village. Being at these events helps spread awareness that support for entrepreneurs is available and it's common for on-the-spot advising to take place.

# Case study: Growing Entrepreneurs

In a Win-Win-Win move, Students in Lebanon and Sweet Home used an innovative modular hydroponics system to grow organic produce while also learning entrepreneurship skills. This program was made possible through a partnership with the Greater Santiam Boys and Girls Clubs, local startup PFFN Produce and RAIN Catalysts.

Clockwise: Facebook post advertising the upcoming sale; produce growing in the pink lighting of the PFFN hydroponics module; Steven Gray of PFFN shows off the marketing and pricing exercises he completed with students.

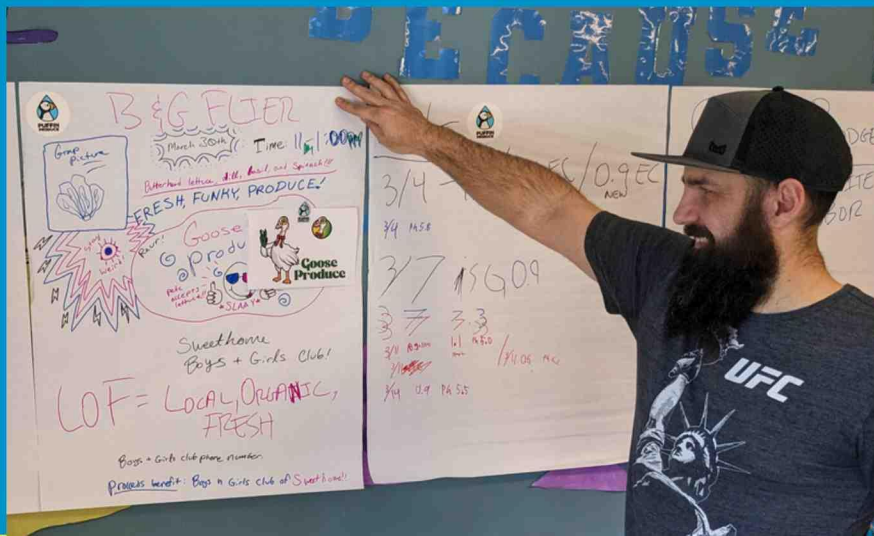
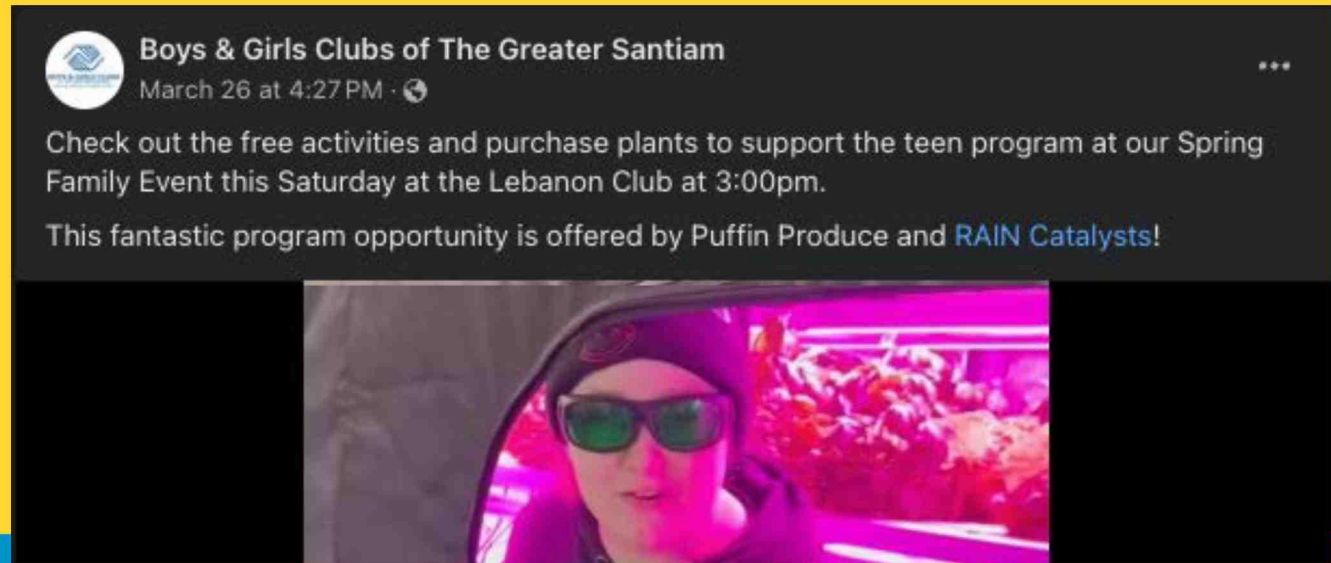

# Case Study: Showcasing local entrepreneurs

It's not uncommon to meet a local entrepreneur who says, "I'm thinking about writing a book." Therefore, RAIN jumped on the opportunity to showcase local author Tai Stith so that others could learn from her experience. Moreover, Tai's book itself tells the innovative story of the area's metals industry and the event was held at the local Adair Village coffee shop that Tai credited with being her go to writing spot.

Below: Thank you notes from Susan of Good Grounds, and Tai Stith:

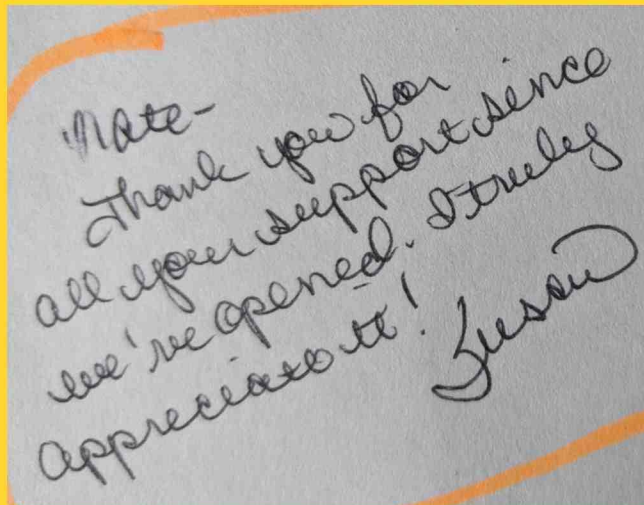

Mate-  
Thank you for  
all your support since  
we've opened. I truly  
appreciate it!  
Susan



Information Correspondence #11  
Meeting Date: 6/10/2024

# BOOK SIGNING

and MEET & GREET with TAI STITH

SATURDAY FEB. 3rd  
11am - 1 pm  
at GOOD GROUNDS  
COFFEE SHOP

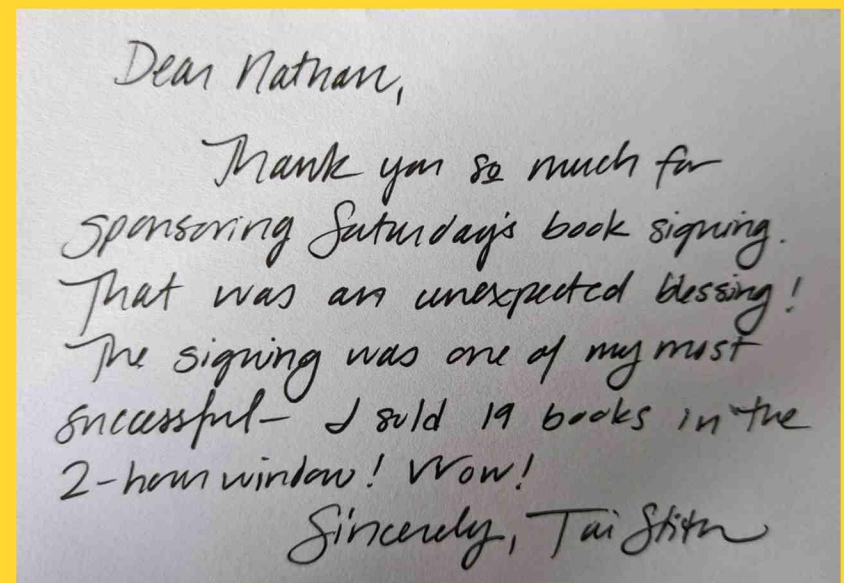
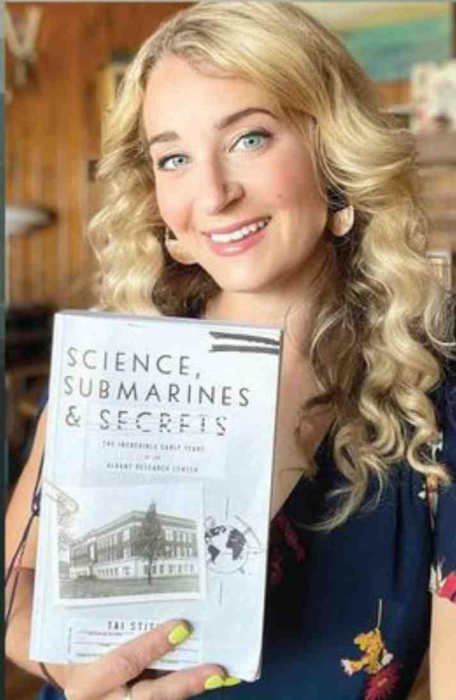
6020 NE William R Carr St.  
Adair Village



Dear Nathan,

Thank you so much for  
sponsoring Saturday's book signing.  
That was an unexpected blessing!  
The signing was one of my most  
successful - I sold 19 books in the  
2-hour window! Wow!

Sincerely, Tai Stith

# Highlight: Facilitating pilots

Entrepreneurs gain tremendous learning and insights when they have the chance to run low-risk pilots of their business ideas. Entrepreneurs need evidence, gained from customers, to validate or invalidate key hypothesis they have about their business. Along with facilitating the PFFN pilot of their system at the Boys & Girls Clubs, RAIN also facilitated a paid pilot for a Sweet Home entrepreneur to test out a birthday party model for his toy making business.

The success of the pilot has led to supporting the entrepreneur with visualizing expansion to a mobile service.

Information Correspondence #11  
Meeting Date: 6/10/2024



# Highlight: Revitalized partnership with WIN



The Willamette Innovators Network (WiN) is a key member of the local entrepreneurial ecosystem. Therefore, a special effort was made to reengage with and strengthen the organization. The result has been an uptick in activity and events, especially with an eye towards rural and traditionally underrepresented entrepreneurs.

"We've appreciated the renewed partnership with RAIN over the past year. Nate and RAIN have brought welcomed support, energy, and insights related to how we can support entrepreneurs across the Linn and Benton Counties."

- Aaron Moore, President, WiN

**MARCH 13 2024**  
**WIN PRESENTS**  
6 - 8 PM @ KELLEY ENGR OSU CAMPUS

**Women of the Willamette Valley:  
Business, Technology, and  
Leadership**

**PANELIST**  
**Smriti Agrawal Zaneveld**  
Founder, President, Chair  
Lazarus 3D, Inc.

PRESENTED IN COLLABORATION WITH

**RAIN** catalysts **swe** Society of Women Engineers  
Support • Education • Action

# What's Next?

RAIN is partnering with the Oregon Biosciences Association, Western University of Health Sciences and Linn Benton Community College to showcase biotech innovation in the region to a statewide audience!



Thank you to our Event and Platinum Sponsors



# What's Next?

Information Correspondence #11  
Meeting Date: 6/10/2024



LIVE: IN CORVALLIS

MONDAY, MAY 20TH | 4:00 PM | ATAMI



Thank You



Oregon State University  
Advantage Accelerator

RAIN  
catalysts



BRASS  
JACKS

ACCOUNTING CONTROLS 101

**Protect your Company  
from Embezzlement  
with this 1.5 hr Training**



Ongoing efforts to help rural entrepreneurs get access to opportunities like pitch feedback through partners at the OSU Advantage Accelerator and the Oregon Entrepreneurs Network; Timely education, through a partnership with the Philomath-based bookkeeping entrepreneurs behind the company, Brass Jacks

# Thank You!



## Partners and Funders

RAIN Catalysts serves entrepreneurs in communities by invitation only. Generous funding and collaboration makes the work possible. Thank you!

Nate Conroy [nate@raincatalysts.org](mailto:nate@raincatalysts.org)



Priority Activity: Identify, engage and provided service to local entrepreneurs and other ecosystem partners (Total = 68)		
*Role in Entrepreneur Ecosystem	City	*Assistance Provided
*Entrepreneur	Corvallis	Identified entrepreneur
*Organization Supporting Entrepreneurs , *Source of Entrepreneurs	Corvallis	Connecting local businesses to receive services through OSU's Design for Social Impact program.
*Entrepreneur	Lebanon	Tech accelerator; lead generation
*Entrepreneur,*Service Provider	Albany	Identified local service provider, self publisher, Amazon sales; sponsored book signing
*Entrepreneur	Adair Village	Hosting Power Hours at their location; connecting with resources
*Entrepreneur,*Service Provider ,*Organization Supporting Entrepreneurs	Corvallis	Identify co-working space
*Mentor		Mentor Identification
*Mentor,*Funder of Entrepreneurs	Corvallis	Mentor recruitment
*Entrepreneur	Corvallis	Connection to RAINcap (fundraising); resources for marketing; connection to local target customer for product testing and marketing production; newsletter promotion; ecosystem scorecard; lining up pitch opportunities
*Entrepreneur	Sweet Home	Connected through Melody at Sweet Home Chamber
*Entrepreneur,*Promotional Partner, *Organization Supporting Entrepreneurs	Monroe	Business model development; Assistance with new business group
*Organization Supporting Entrepreneurs , *Promotional Partner,*Service Provider ,*Source of Entrepreneurs	Lebanon	Engaged regarding partnership to support Latino entrepreneurs.
*Organization Supporting Entrepreneurs , *Service Provider		Shaping the South Corvallis Food Hub to serve local rural entrepreneurs
*Mentor,*Entrepreneur	Corvallis	Mentor Identification
*Entrepreneur,*Mentor,*Promotional Partner, *Source of Entrepreneurs		Mentor recruitment
*Entrepreneur	Corvallis	Attending women entrepreneurship panel
*Entrepreneur	Corvallis	Marketing, referrals coaching
*Entrepreneur,*Service Provider	Sweet Home	Business model; connections to potential mentor and business partners; customer discovery assistance; access to customers; access to Chamber
*Entrepreneur	Corvallis	Advising: customer development; access to sales opportunities
*Entrepreneur	Corvallis	Support to attend women in entrepreneurship event
*Source of Entrepreneurs	Lebanon	Identify as ecosystem partner
*Entrepreneur	Sweet Home	Adair Village Bazaar; candidate for story; business model development; connected to potential community partners
*Entrepreneur	Halsey	Advising on bookkeeping; mileage and receipt tracking
*Entrepreneur	Corvallis	Identified
*Entrepreneur	Adair Village	Business model; Customer discovery; connection to fire houses
*Service Provider	Lebanon	Identified service provider; growth financial advising, connections
*Entrepreneur	Sweet Home	Met with and consulted on go to market strategy. Provided coaching on completing customer discovery; pitch coaching and led to pitch competition participation; financial planning through LivePlan; connection to manufacturing assistance; ecosystem scorecard; website coaching
*Entrepreneur	Brownsville	Provided coaching on value proposition design, pitching to investors, and introduced to mentors. Entrepreneur attended multiple startup events; coaching on business plan, marketing, and value proposition validation; assistance with pitch deck; connection to business plan development assistance; business plan feedback; investment assistance; connected to SBDC; connected to legal assistance; connected to loan assistance
*Entrepreneur,*Service Provider	Sweet Home	Attended most of Pre-X. Has several business ideas she is working on. Assisting as required; RAINmaker 2022; Attended Money Beliefs talk
*Entrepreneur	Corvallis	Coaching - path to market; interested to participate in Spring Biz Rush
*Entrepreneur	Harrisburg	Guidance with the South Corvallis Food Hub
*Entrepreneur	Sisters	Connections to potential partners; business model development

*Entrepreneur	Corvallis	Reached out on Oregon RAIN website. Had initial consulte meeting and connected to multiple stakeholders in the region. Helped apply to the Bend Venture Conference where they were selected to pitch. Connected to various investment funds in Oregon. Attended LB Holiday Showcase. Completed Anvil Media Marketing Kit training. Connected to Philomath stakeholders; connected to Energy Trust of Oregon; promotion of ribbon cutting; connection to lighting upgrade
*Entrepreneur	Corvallis	Identified
*Funder of Entrepreneurs,*Organization Supporting Entrepreneurs ,*Promotional Partner,*Source of Entrepreneurs,*Speaker	Portland	Partnering to highlight state and regional bioscience innovation
*Entrepreneur	Corvallis	Business advising -- app development; connection to mentors; connection to OSU supports; ecosystem scorecard; connection to potential parters; business model testing
*Entrepreneur	Corvallis	Early stage coaching; entrepreneurial mindset
*Entrepreneur	Corvallis	Identified
*Champion of RAIN	Corvallis	Business culture; funnels
*Entrepreneur	Corvallis	Connected to Skip and Bill Byers. Applied and accepted into RAINmaker Accelerator program. Graduated program. Participating in Anvil Media Marketing Kit training; Reconnection with Corey for pitch coaching
*Mentor	Corvallis	Mentor identification
*Entrepreneur	Corvallis	RAINmaker 2022; WIN event ticket; connection to potential partners
*Entrepreneur	Lebanon	Business model coaching; connections for customer discovery and sales; tech accelerator; access to the Lebanon Chamber of Commerce
*Entrepreneur	Hood River	Mentor identified: drone technology; solopreneur support; engineering roadmaps; market assessment
*Mentor	Corvallis	Mentor identified
*Entrepreneur,*Organization Supporting Entrepreneurs ,*Promotional Partner,*Source of Entrepreneurs	Corvallis	Ecosystem building: Partner for local entrepreneurs
*Entrepreneur	Lebanon	Attended and graduated Pre-X. Helping formulate business plan and build prototype; WIN event ticket
*Entrepreneur	Lebanon	Attended E-commerce and Business plan workshops; business model development; customer development connections; sponsored to take the SBDC start your business in 6 days course
*Entrepreneur	Philomath	Sponsorship for SBDC: Starting Your Business in 6 Weeks
*Entrepreneur	Corvallis	Connection at Adair Village Bazaar; connection to Benton County commercial kitchen.
*Entrepreneur	Corvallis	Provided info on PPP program. Attended multiple workshops, and presented on mental health for entrepreneurs. Applied and accepted into RAINmaker Accelerator program. Graduated Program. Completed Anvil Media Marketing Kit training; connection to mentoring regarding joint ventures; advising on growing sales team, acquisitions
*Entrepreneur,*Organization Supporting Entrepreneurs	Lebanon	Holiday Market Vendor Bootcamp; Microenterprise Covid grant; connection to grant writing for equipment;
*Entrepreneur	Corvallis	path to market advising
*Entrepreneur	Corvallis	Customer development; path to market
*Entrepreneur,*Champion of RAIN	Lebanon	Incorporation; connection to legal assistance; connection to grant writing assistance; assistance with Chamber of Commerce Membership
*Entrepreneur,*Service Provider ,*Mentor	Albany	Connecting with local mentors and fellow creatives; support setting up ongoing creatives meetup
*Organization Supporting Entrepreneurs , *Service Provider	Corvallis	Partner in planning the South Corvallis Food Hub to serve entrepreneurs

Priority Activity: Implement and attend community events driven by entrepreneur requests (Total = 32)						
Date	Event Name	Venue	City	County	Attendance	Host Organization
3/30/2024	Eggstravaganza labeling	County Park	Adair Village	Benton	8 [1]	The Village
3/21/2024	Growing Entrepreneurs	Boys & Girls Club	Lebanon	Linn	5	RAIN / PFFN
3/21/2024	Growing Entrepreneurs	Boys & Girls Club	Sweet Home	Linn	7	RAIN / PFFN
3/18/2024	Growing Entrepreneurs	Boys & Girls Club	Lebanon	Linn	5	RAIN / PFFN
3/18/2024	Growing Entrepreneurs	Boys & Girls Club	Sweet Home	Linn	7	RAIN / PFFN
3/13/2024	Women of the Willamette Valley: Business, Technology, and Leadership	Oregon State University	Corvallis	Benton	26	RAIN / Willamette Innovators Network
3/11/2024	Growing Entrepreneurs	Boys & Girls Club	Lebanon	Linn	5	RAIN / PFFN
3/11/2024	Growing Entrepreneurs	Boys & Girls Club	Sweet Home	Linn	7	RAIN / PFFN
3/7/2024	Growing Entrepreneurs	Boys & Girls Club	Lebanon	Linn	5	RAIN / PFFN
3/7/2024	Growing Entrepreneurs	Boys & Girls Club	Sweet Home	Linn	7	RAIN / PFFN
3/4/2024	Growing Entrepreneurs	Boys & Girls Club	Lebanon	Linn	5	RAIN / PFFN
3/4/2024	Growing Entrepreneurs	Boys & Girls Club	Sweet Home	Linn	7	RAIN / PFFN
3/2/2024	Power Hours	Good Grounds	Adair Village	Benton	1	RAIN
2/29/2024	Growing Entrepreneurs	Boys & Girls Club	Lebanon	Linn	3	RAIN / PFFN
2/29/2024	Growing Entrepreneurs	Boys & Girls Club	Sweet Home	Linn	5	RAIN / PFFN
2/27/2024	Growing Entrepreneurs	Boys & Girls Club	Lebanon	Linn	3	RAIN / PFFN
2/27/2024	Growing Entrepreneurs	Boys & Girls Club	Sweet Home	Linn	5	RAIN / PFFN
2/24/2024	Power Hours	Good Grounds	Adair Village	Benton	1	RAIN
2/17/2024	Power Hours	Good Grounds	Adair Village	Benton	1	RAIN
2/15/2024	Business After Hours	COMP-NW	Lebanon	Linn	40	Lebanon Chamber of Commerce
2/13/2024	The Alliance -- Business networking	The Suite Space	Corvallis	Linn	6	The Alliance
2/10/2024	Power Hours	Good Grounds	Adair Village	Benton	3	RAIN
2/8/2024	OSU Mentoring	Zoom	Corvallis	Benton	12	OSU
2/7/2024	Federal Energy Hub Plan	PSU	Portland		40	PSU
2/3/2024	Author Meet & Greet	Good Grounds	Adair Village	Benton	24	RAIN
2/2/2024	Mentoring with RAIN Catalysts	The Vue	Corvallis	Benton	30	Rotary Club of Corvallis
1/30/2024	Supporting Immigrant Entrepreneurs	New Morning Bakery	Corvallis	Benton	3	RAIN

Priority Activity: Implement and attend community events driven by entrepreneur requests (Total = 32)						
Date	Event Name	Venue	City	County	Attendance	Host Organization
1/27/2024	Power Hours	Good Grounds	Adair Village	Benton	2	RAIN
1/25/2024	Corvallis Food Hub	Zoom	Corvallis	Benton	3	Tuttle Consults
1/20/2024	Power Hours	Good Grounds	Adair Village	Benton	2	RAIN
1/11/2024	BAM Meeting	BQPM	Monroe	Benton	4	BAM
1/6/2024	Power Hours	Good Grounds	Adair Village	Benton	1	RAIN

**MINUTES  
PHILOMATH  
INCLUSIVITY AD HOC COMMITTEE**

April 23, 2024

Council Chambers; Philomath City Hall  
980 Applegate St., Philomath, OR

I. ATTENDANCE

Meeting Called to order at 5:32.  
Committee Members: Jessica Andrade, Rose Bricker, Jane Sherwood, Christopher  
McMorran, Zina Allen, Amanda Polley, and Laurie Lehman. Staff: Chris Workman

II. APPROVAL OF MINUTES

A. March 26, 2024 minutes - Consensus to approve (6 present)

III. URGENT BUSINESS -None

IV. BUSINESS

A. Updates & Announcements

- Start Time: 5:35 p.m.
- May 1, PHS Baseball game will have Paul J. Cochran recognition ceremony
- May 11, Mt. union Cemetery will have Memorial Day and Armed Services Day ceremony 10:00 a.m.-12:00 p.m.
- May 18, 45<sup>th</sup> Annual Pow Wow at OSU Gill Coliseum
- May 14, PHS Event, Asian American Pacific Islander Month presentation
- April 27, OSU event by Oregon Past Abolition Collective

B. Inclusivity Calendar: May-August Recap

- Start Time: 5:45 p.m.
- Holocaust Remembrance follows the Jewish calendar, so it will be in May this year.
- Review of calendar provided in the packet with assignments for social media posts and farmers market booth
- Agreement to switch the first to clauses in the American Indian Pacific Islander social media post.
- Use the name “Happy Independence Day” instead of “4<sup>th</sup> of July”
- Age-friendly proclamation to go before the Council in August for consideration.
- Christopher to sign Inclusivity up for farmers market table on August 18th

C. Inclusivity Proclamation Updates & Discussion

- Start Time: 6:06 p.m.
- Concerns around some of the language being offensive were discussed.
- Agreement to label drafts more clearly in future meeting packet materials to avoid confusion.

D. Age-friendly communities discussion

Start Time: 6:18 p.m.

- 47 • Discussion about joining the Age-Friendly Community network, starting with a
- 48 resolution by the council and a letter from the mayor.
- 49 • Jane offered to prepare a poster that asks “How can we make Philomath better for
- 50 everyone” that people can write suggestions on during the Music in the Park events
- 51 • Discussion about language to be included in the draft proclamation Jane is preparing
- 52 • Recommendation to have the Council put out the poster at the Farmers Market
- 53

54 E. Heritage Celebration/Awareness Banners

55 Start Time: 6:27 p.m.

- 56 • Update on status of banners for each month was provided and the list of future
- 57 banners for each month were discussed.
- 58 • Discussion about timing and approval process. Concerns were raised about having to
- 59 bring multiple iterations of each banner back to the full committee every time.
- 60

61 F. PRIDE Event

62 Start Time: 6:34 p.m.

- 63 • Rose reviewed status of planning efforts for the event.
- 64 • Chris is working to schedule training with White Bird Clinic for de-escalation training.
- 65 • Looking for yard games
- 66 • Looking to house PRIDE in a different non-profit organization next year
- 67 • Philomath Pride Collective is going to have a table at the Benton County Youth Suicide
- 68 Prevention event on May 25
- 69

70 G. Community Co-Chair Selection

71 Start Time: 6:51 p.m.

- 72 • Amanda Polley volunteered to serve as co-chair for the next three months, with
- 73 enthusiasm.
- 74

75 V. NEXT MEETING

76 A. May 28, 2024, at 5:30 PM

77 B. Agenda item topics –DEI training survey

78

79 VI. ADJOURNMENT - Meeting adjourned at 6:43 p.m.

**MINUTES**  
**PHILOMATH**  
**INCLUSIVITY AD HOC COMMITTEE**  
May 28, 2024

1  
2  
3  
4  
5  
6  
7  
8  
9  
10  
11  
12  
13  
14  
15  
16  
17  
18  
19  
20  
21  
22  
23  
24  
25  
26  
27  
28  
29  
30  
31  
32  
33  
34  
35  
36  
37  
38  
39  
40  
41  
42  
43  
44  
45  
46  
47  
48  
49  
50

I. ATTENDANCE

Start Time: 5:31

Diane Crocker, Jane Sherwood, Nora Smith, Rose Bricker, Jessica Andrade, Christopher McMorrان, Chris Workman (staff)

II. URGENT BUSINESS

None

III. BUSINESS

A. Updates & Announcements

Start Time: 5:33

- Bringing the World Together event announced

Lauri Lehman arrived.

B. Inclusivity Proclamation Approval

Start Time: 5:36

- Discussion about using OSU language, but swapping out “OSU” with “City of Philomath,” instead of paraphrasing.
- Proclamation needs to be approved at today’s meeting in order to get before the City Council at the June meeting of the Council.
- Concerns about use of the terms “whereas” and if they should be removed from the proclamation format or not.
- Discussion to remove the second whereas clause in order to avoid future concerns.

Consensus to swap out the first clause and remove the second clause (8 present)

C. Heritage Celebration/Awareness Banners

Start Time: 5:21

- Diane and Zina have been working with the graphic artist and things are going well.
- Request to have design come to the Inclusivity Committee before it gets printed.
- Discussions about timing and urgency to complete the project this year and role of the subcommittee.

Consensus to have the subcommittee continue with June and July’s banners, but to bring future banners back to the IC for approval before printing

D. Age-friendly Communities Proclamation

Start Time: 5:38

- Jane discussed the current status and took recommendations for minor word changes and punctuation.
- Poster at Music in the Park event got several comments written on it and those comments were shared.
- Recommendation to add age-friendly resources to the library lobby area

E. PRIDE Event Updates

Start Time: 5:46

- Benton County Health paying for free mud oven pizza and cost for shirts
- Benton County Mental Health is sponsoring zen den
- Looking for yard games

- 51 • Benton County Historical Museum is putting together a “walk through history”
- 52 • BABS is partnering with Milk skatepark to hold events at the skate park during the
- 53 event
- 54 • Sign making party this weekend; supplies, paint and brushes wanted
- 55 • Training June 8<sup>th</sup> to be finalized for de-escalation via zoom
- 56 • Online volunteer signup form was emailed out and available online.
- 57 • Inclusivity Committee can help by distributing fliers and speaking with businesses
- 58 willing to donate for Bingo prizes. Digital flier to be shared by Rose.
- 59 • Social media has been set up to promote the event.

60 F. Community Outreach Sharing

61 Start Time: 5:56

- 62 • “Paint the bones” event in Corvallis discussed
- 63 • Discussion of making Cinco de Mayo more inclusive of all Latin diversities
- 64 • Discussion about the flag hoisted at the new veterans park.

65  
66 IV. NEXT MEETING

67 A. June 25, 2024, at 5:30 PM

68 B. Agenda item topic requests

- 69 • Identifying definition of subcommittee and
- 70 • Age-friendly proclamation
- 71 • Review of Pride Event

72  
73 V. ADJOURNMENT

74 Meeting Adjourned 6:33

DRAFT